



EDGE 2

IoT LPWA Solution

Industrial LTE-M/NB-IoT Edge Node

User's Guide

All Rights Reserved

Dissemination or reproduction of this document, or its contents, is not authorized except where expressly permitted. Violators are liable for damages. All rights reserved, for the purposes of patent application or trademark registration.

Disclaimer of Liability

The information contained in this document is subject to change without notice. EtherWAN is not liable for any errors or omissions contained herein or for resulting damage in connection with the information provided in this manual.

Registered Trademarks

The following words and phrases are registered Trademarks of EtherWAN Systems Inc.

EtherWAN

All other Trademarks are property of their respective owners.

Warranty

For details on the EtherWAN warranty replacement policy, please visit our web site at:

www.etherwan.com

Contact EtherWAN Systems

8F., No.2, Alley 6, Lane 235, Baoqiao Rd.

Xindian District, New Taipei City 231

Taiwan

Tel: +886 -2- 6629-8986

Email: info@etherwan.com.tw

Chapter 1 Introduction.....	4
1.1 Introduction	4
1.2 Contents List.....	5
1.2.1 Package Contents	5
1.2.2 Optional Accessories.....	5
1.3 Hardware Configuration	6
1.4 LED Indication	7
1.5 Installation & Maintenance Notice	8
1.5.1 SYSTEM REQUIREMENTS.....	8
1.5.2 WARNING	8
1.5.4 Product Information for CE RED Requirements	10
1.6 Hardware Installation	12
1.6.1 Open the Top Cover	12
1.6.2 Insert SIM Card	14
1.6.3 Install Battery.....	15
1.6.4 Connecting to External Devices.....	18
1.6.5 Connecting Console Port for PC Configuration Tool	26
1.6.6 Power On the EDGE 2	28
1.6.7 Setup with Windows-based Configuration Tool.....	30
1.6.8 Device Mount and Screw Back the Top Cover.....	32
Chapter 2 Device Configuration	33
2.1 Device Status.....	33
2.2 LPWA Configuration.....	34
2.3 I/O Configuration.....	35
2.4 Modbus Configuration.....	37
2.5 Schedule Configuration	39
2.6 Server Configuration.....	42
2.7 System Configuration	46
Chapter 3 Data and Command Formats	48
3.1 Data Log Format	48
3.2 Downlink Command Format.....	51
Contact Information	53

Chapter 1 Introduction

1.1 Introduction

Congratulations on your purchase of this outstanding product: Industrial LTE-M/NB-IoT Edge Node. For IoT applications, EtherWAN's EDGE 2 is absolutely the right choice. With built-in world-class LPWA module*¹, you just need to insert a SIM card from a local mobile carrier to get to remote servers on the internet.

The EDGE 2 is a cost-effective low complexity solution for simple data acquisition and wireless telemetry. The advanced LPWA, either Cat.M1 or NB1, is optimized for low bandwidth IoT traffic and leverages existing 4G infrastructure to transmit data at low data rates. It allows massive deployment of wireless IoT with carrier-level security. Thanks to the power saving technology, the EDGE 2 has ultra-low power consumption which allows it to operate on a single battery for years*².

Main Features:

- Simple device with various interfaces (AI / DI / RS-485) for IoT field data acquisition.
- Storage of the meter/sensor readings in non-volatile memory of the data logger.
- Transfer of logged data to designated remote server by schedule rule, or on an event at the site.
- Internal battery-powered design for easy deployment; Low power consumption and can operate without changing the battery for years.
- Automatic issuing of low battery power alerts to remote server for device or battery replacement.
- Configuring of the data logger via a PC with a convenient configuration utility.
- Water-resistant, dust-resistant IP65 enclosure for installing in severe environments.

Before you install and use this product, please read this manual in detail.

1 EDGE1 for LoRa; EDGE 2 for Cat.M1/NB1(NB-IoT).







2 The battery lifespan depends on actual usage (frequency of data logging, and data uploading) of the data logger.

EDGE 2

1.2 Contents List

1.2.1 Package Contents

#Standard Package

Items	Description	Contents	Quantity
1	EDGE 2 LTE-M/NB-IoT Edge Node		1pcs
2	Battery		1pcs
3	Cable Tie		2pcs
4	AI Jumper		3pcs
5	Water/Dust-proof Stopper		3pcs
6	Bluetooth Module		Used for wireless configuration

1.2.2 Optional Accessories

#Optional parts (these parts are sold separately)

Items	Description	Contents	Comments
1	USB-to-Serial Console Cable		Used for wired configuration

These parts are sold separately. If necessary, please contact us via info@etherwan.com.tw

1.3 Hardware Configuration

➤ Front View



1.4 LED Indication



LED Icon	Indication	LED Color	Description
LED	Device Status	Blue / Red	Steady OFF: Device is powered off. Red Steady ON: Device is booted up, but WAN not connected yet. Blue Steady ON: Device is booted up, and connected to WAN. Red Flash: Battery Low, or no SIM card while device is not in sleep mode. Blue and Red Steady ON: Device is in Recovery mode, or Firmware is upgrading

1.5 Installation & Maintenance Notice

1.5.1 SYSTEM REQUIREMENTS

Network Requirements	<ul style="list-style-type: none">• ISP provided SIM card for 4G LPWA service
Configuration Tool Requirements	Computer with the following: <ul style="list-style-type: none">• Windows®7 or Windows 10• An installed Ethernet adapter• A USB 2.0 or later interface for serial console, or• Bluetooth 4.x, or later for wireless console

1.5.2 WARNING



Attention

- Only use the battery that comes with the package or the external DC Power Supply that complies with the device specifications. Using a different voltage rating power adaptor is dangerous and may damage the product.
- DO NOT remove or repair the control board by yourself. If the product is too hot or malfunctioning, turn off the device and have it repaired at a qualified service center.
- Place the product on a stable surface, or screw it to a solid plate or wall.

Federal Communication Commission Interference Statement

This device complies with Part 15 of the FCC Rules. Operation is subject to the following two conditions: (1) This device may not cause harmful interference, and (2) this device must accept any interference received, including interference that may cause undesired operation.

This equipment has been tested and found to comply with the limits for a Class B digital device, pursuant to Part 15 of the FCC Rules. These limits are designed to provide reasonable protection against harmful interference in a residential installation. This equipment generates, uses and can radiate radio frequency energy and, if not installed and used in accordance with the instructions, may cause harmful interference to radio communications. However, there is no guarantee that interference will not occur in a particular installation. If this equipment does cause harmful interference to radio or television reception, which can be determined by turning the equipment off and on, the user is encouraged to try to correct the interference by one of the following measures:

- Reorient or relocate the receiving antenna.
- Increase the separation between the equipment and receiver.
- Connect the equipment into an outlet on a circuit different from that to which the receiver is connected.
- Consult the dealer or an experienced radio/TV technician for help.

FCC Caution: Any changes or modifications not expressly approved by the party responsible for compliance could void the user's authority to operate this equipment.

This transmitter must not be co-located or operating in conjunction with any other antenna or transmitter.

FOR PORTABLE DEVICE USAGE (<20m from body/SAR needed)

Radiation Exposure Statement:

The product comply with the FCC portable RF exposure limit set forth for an uncontrolled environment and are safe for intended operation as described in this manual. The further RF exposure reduction can be achieved if the product can be kept as far as possible from the user body or set the device to lower output power if such function is available.

FOR MOBILE DEVICE USAGE (>20cm/low power)

Radiation Exposure Statement:

This equipment complies with FCC radiation exposure limits set forth for an uncontrolled environment. This equipment should be installed and operated with minimum distance 20cm between the radiator & your body.

FOR COUNTRY CODE SELECTION USAGE (WLAN DEVICES)

Note: The country code selection is for non-US models only and is not available to US models. Per FCC regulation, all Wi-Fi products marketed in US must be fixed to US operation channels only.

1.5.4 Product Information for CE RED Requirements

The following product information is required to be presented in product User Manual for latest CE RED requirements.³

(1) Frequency Band & Maximum Power

1.a Frequency Band for Cellular Connection (for BC66 Version)

Band number	Operating Frequency	Max output power
LTE FDD BAND 1	Uplink: 1920-1980 MHz Downlink: 2110-2170 MHz	23 ±2 dBm
LTE FDD BAND 2	Uplink: 1850-1910 MHz Downlink: 1930-1990 MHz	
LTE FDD BAND 3	Uplink: 1710-1785 MHz Downlink: 1805-1880 MHz	
LTE FDD BAND 5	Uplink: 824-849 MHz Downlink: 869-894 MHz	
LTE FDD BAND 8	Uplink: 880-915 MHz Downlink: 925-960 MHz	
LTE FDD BAND 12	Uplink: 699-716 MHz Downlink: 729-746 MHz	
LTE FDD BAND 13	Uplink: 777-787 MHz Downlink: 746-756 MHz	
LTE FDD BAND 18	Uplink: 815-830 MHz Downlink: 860-875 MHz	
LTE FDD BAND 19	Uplink: 830-845 MHz Downlink: 875-890 MHz	
LTE FDD BAND 20	Uplink: 832-862 MHz Downlink: 791-821 MHz	
LTE FDD BAND 25	Uplink: 1850-1915 MHz Downlink: 1930-1995 MHz	
LTE FDD BAND 28	Uplink: 703-748 MHz Downlink: 758-803 MHz	

1.b Frequency Band for Cellular Connection (for BG96 version)

Band number	Operating Frequency	Max output power
LTE FDD BAND 1	Uplink: 1920-1980 MHz Downlink: 2110-2170 MHz	23 ±2 dBm
LTE FDD BAND 2	Uplink: 1850-1910 MHz Downlink: 1930-1990 MHz	
LTE FDD BAND 3	Uplink: 1710-1785 MHz	

³ The information presented in this section is ONLY valid for the EU/EFTA regional version. For those non-CE/EFTA versions, please refer to the corresponding product specification.

	Downlink: 1805-1880 MHz
LTE FDD BAND 5	Uplink: 824-849 MHz Downlink: 869-894 MHz
LTE FDD BAND 8	Uplink: 880-915 MHz Downlink: 925-960 MHz
LTE FDD BAND 12	Uplink: 699-716 MHz Downlink: 729-746 MHz
LTE FDD BAND 13	Uplink: 777-787 MHz Downlink: 746-756 MHz
LTE FDD BAND 18	Uplink: 815-830 MHz Downlink: 860-875 MHz
LTE FDD BAND 19	Uplink: 830-845 MHz Downlink: 875-890 MHz
LTE FDD BAND 20	Uplink: 832-862 MHz Downlink: 791-821 MHz
LTE FDD BAND 28	Uplink: 703-748 MHz Downlink: 758-803 MHz

2. Frequency Band for Bluetooth Connection (feature with optional Bluetooth module)

Band	Operating Frequency	Max. Output Power (EIRP)
2.4G	2.4 – 2.485 GHz	4 mW

(2) RF Exposure Statements

The antenna of the product, under normal use condition, is at least 20 cm away from the body of user.

(3) Unit Mounting Notice

The product is suitable for mounting at heights <= 2m (approx. 6 ft), or in a cabinet.

Ensure the unit is fixed tightly to reduce the likelihood of injury due to exposure to mechanical hazards if dropped.

(4) Manufacturer Information

Manufacturer Name: EtherWAN Systems, Inc.

Manufacturer Address: 8F, No.2, Alley 6, Lane 235, Baoqiao Rd., Xindian Dist., New Taipei City 231, Taiwan (R.O.C.)

1.6 Hardware Installation

The following list shows the available hardware ports of the EDGE 2:

- **SIM Slot:** 1 nano-SIM (4FF)
- **Analog Input:** 3 AI ports (supports 0-10V / 4-20mA)
- **Digital Input:** 2 DI ports (isolated, "Logic 0": 0~2V, "Logic 1": 5V~30V; supports Pulse Counter, Dry Contact)
- **Digital Output:** 1 DO port (isolated, Non-Relayed Output, Maximum 24V/300mA)
- **Field Bus:** 1 RS-485 for Modbus RTU
- **Console Port:** 1 RS-232 for device configuration
- **Wake-up Port:** 1 internal Reed Switch, and
1 dedicated DI for external device wake-up triggering.
- **Power Source :** 4000mAh 3.6V Li-SOCL2 battery (ER18505, A Size), or external 5V~12V DC power.

This section describes how to install and configure the hardware.

1.6.1 Open the Top Cover

The EDGE 2 is designed for universal data logging use. There are various interfaces for connecting to your field devices, all enclosed with an IP65 grade enclosure. All the connection cables to the field devices must be wired properly through the M16 connectors.

Therefore, prior to connecting and configuring the EDGE 2, you must open the top cover to get access to the control board.

Unscrew the four screws and remove the top cover to the side carefully.

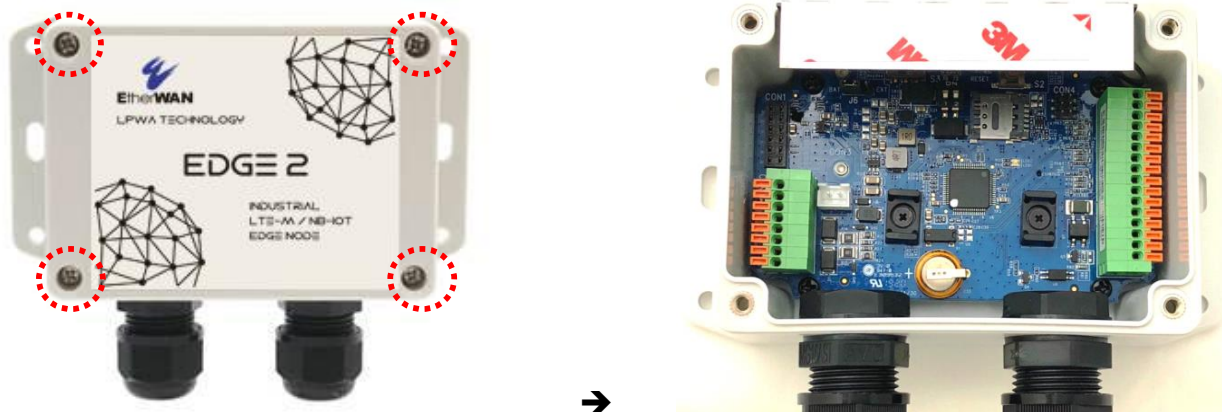

You can see there are many hardware connectors available for you to configure. There are two spring-type terminal blocks, a nano-SIM slot, battery stand, power socket and switch, etc...

➤ Internal View

After removing the top cover, you can see all the available hardware connectors.

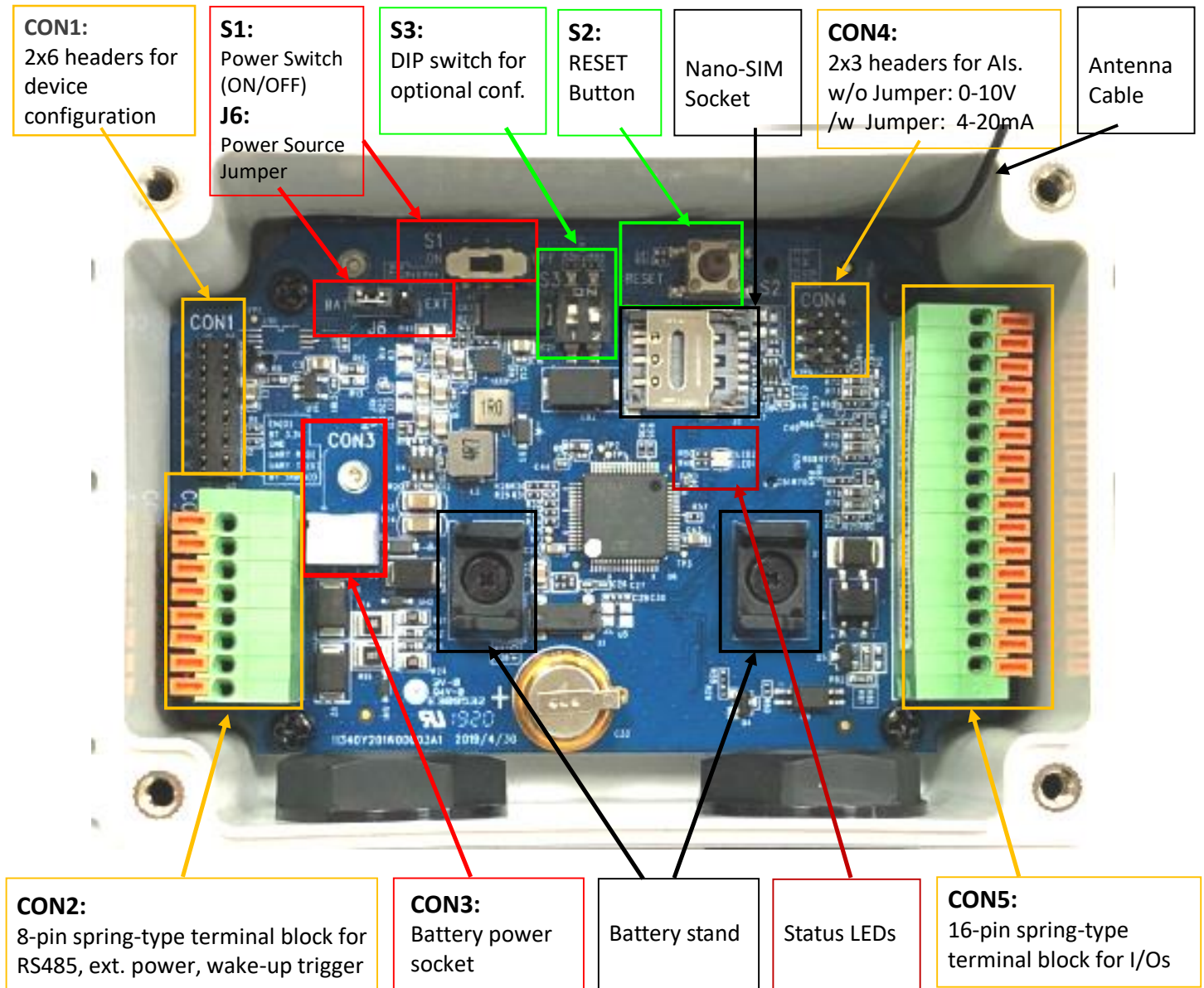

Note:

1. By default **S1** (Power Switch) is in **OFF** state, and **J6** (Power Source) is in **BAT** state.
2. Before proceed to the following hardware configuration details, be sure to keep **S1** at **OFF** state till the moment you finish the required configuration and need to power up the device.
3. The **RESET** button provides a quick way to reboot the device.

1.6.2 Insert SIM Card

WARNING: BEFORE INSERTING OR CHANGING THE SIM CARD, PLEASE MAKE SURE THAT POWER TO THE DEVICE IS SWITCHED OFF.

The SIM card slot is located at the upper-right corner of the control board. Please follow the instructions to insert a SIM card (4FF nano-SIM).

Step 1:

Follow red arrow to unlock SIM holder.

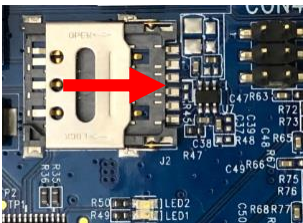

Step 2:

Lift up SIM holder, and insert 4FF nano-SIM card.

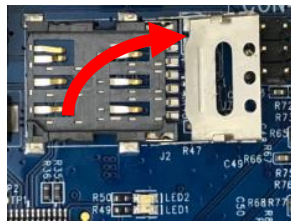

Step 3:

Put back SIM holder, and follow red arrow to lock SIM holder.

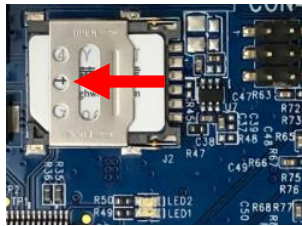

1.6.3 Install Battery

Step 1:

Insert the two cable ties through the battery stands.

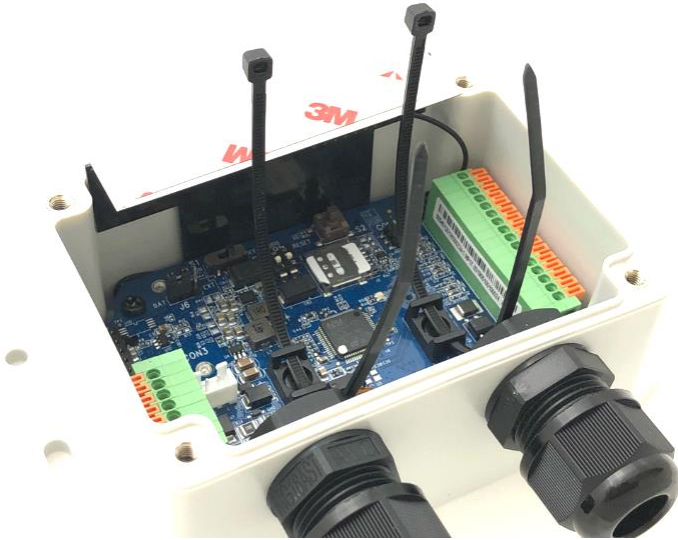

Step 2:

Load the battery over the stands as illustrated, and fasten each cable tie tightly.

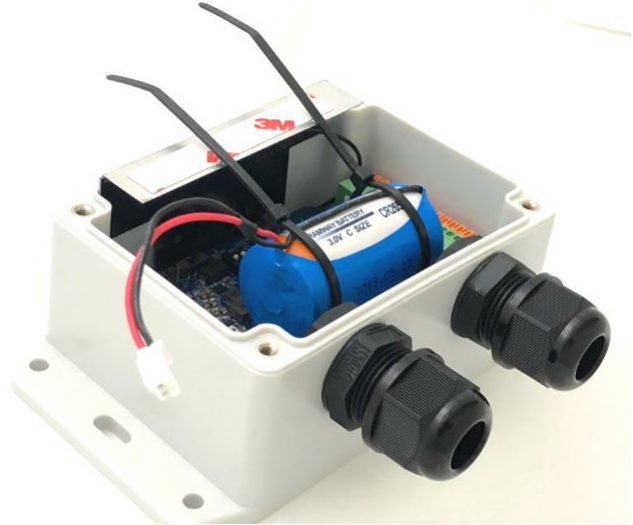

Step 3:

Cut off the extra cable tie, and plug the power cable onto **CON3** (Battery Power Socket).

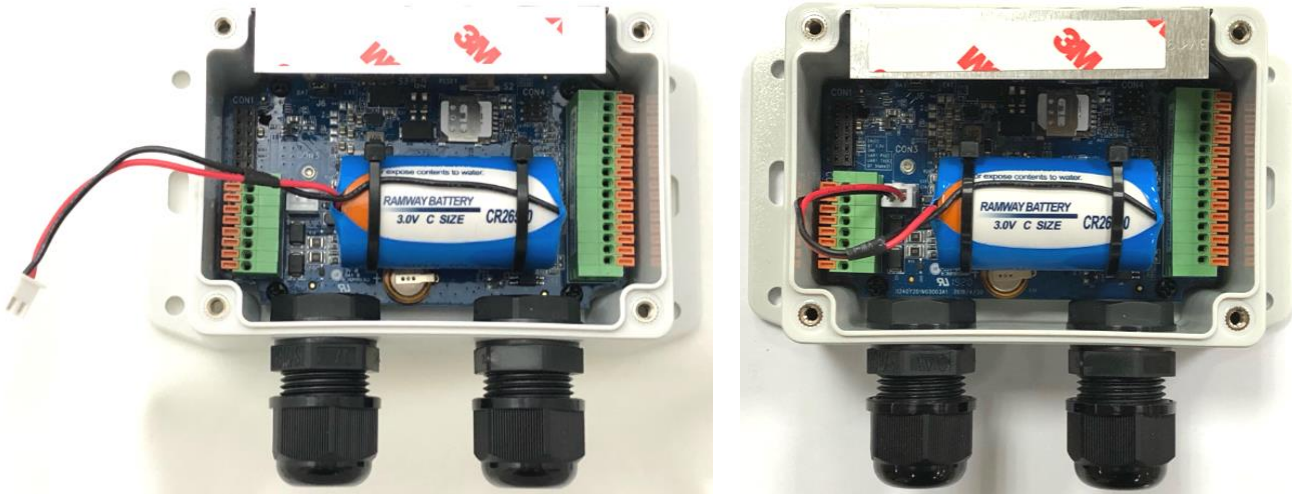

WARNING :

1. It is strictly forbidden to have the battery positive or negative short circuit, charging, discharging, heated over $100\text{ }^{\circ}\text{C}$, removed, or disassembled. Doing any of these may cause explosion, combustion, internal acid leakage.
2. The Li-SOCL2 battery is an one-time use battery. DO NOT re-charge, crush, or disassemble the battery in any situation.
3. Discharged batteries are hazardous waste, and should be recycled or brought to a hazardous waste disposal facility.
4. Battery Replacement: You can purchase a new (full power) battery and replace it by yourself. The Battery Specification and Power pin must be compliant with the original design:
 - A. 4000mAh 3.6V Li-SOCL2 battery (ER18505, A Size) with power cable.
 - B. Re-use the power connector: Red pin for V+, and Black pin for GND.
 - C. Follow the Battery Installation procedure mentioned above.

Li-SOCL2 Battery Specification

If you purchase the battery from 3rd-party, please make sure it comply to the following electrical characteristics. Not only Nominal Capacity and Voltage, but also Max. Continuous Current and Max. Pulse Capacity specifications are important.

ELECTRICAL CHARACTERISTICS

Nominal Capacity	4Ah
(2mA ,+25°C 2V cut off.The capacity restored by the cell varies according to current drain, temperature and cut-off)	
Nominal Voltage	3.6V
Max.Continuous Current	100mA
Max.Pulse Capability	200mA
Operating Temperature Range	- 60°C~+85°C
(Operation at temperature different from ambient may lead to reduced capacity and lower voltage plateau readings)	

1.6.4 Connecting to External Devices

There are many available I/O interfaces for connecting the EDGE 2 data logger to external devices.

As indicated in the I/O pinout sheet, you can easily find out the pin location and connect to your devices with appropriate conductive cables. However, there are only two dual-hole M16 water/dust-proof connectors for you to route the conductive cables out of the enclosure. That is, up to four cables can be routed to connect external devices.

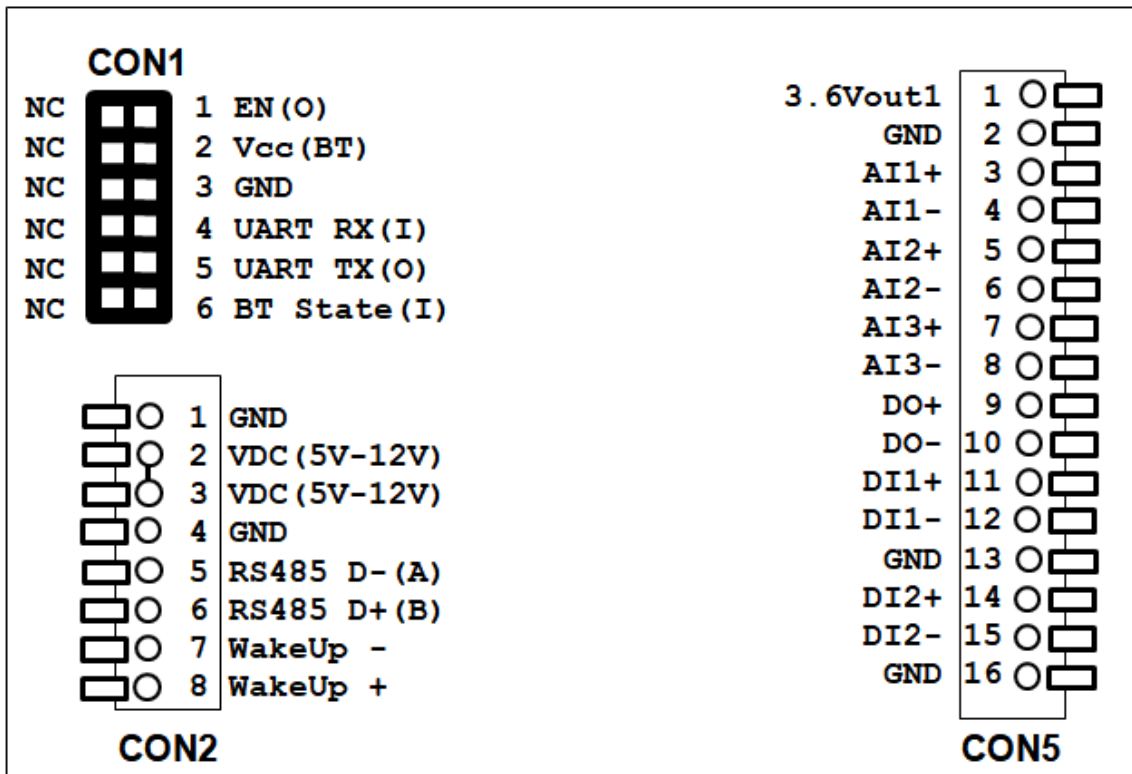

Run External cable to desired connectors:

Step 1: a) Find a conductive cable with 15mm tinned terminals; b) Remove the external part of the M16 connector; c) Run the cable through the external parts as indicated below.

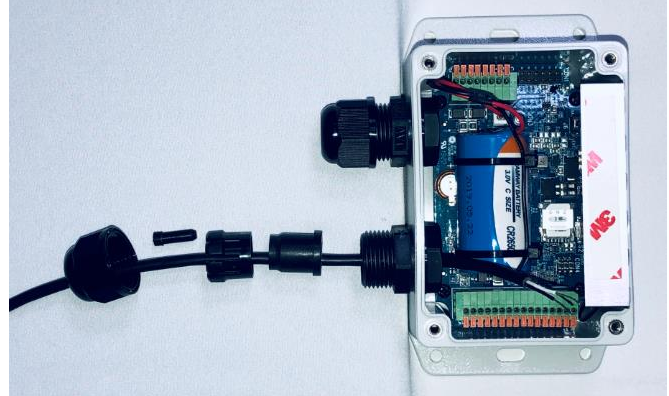

Step 2: a) Place the tinned terminal over the connector; b) Use a flathead screwdriver and push down the clip; c) Insert the tinned terminal to very bottom; d) Release and verify the terminal is well locked.

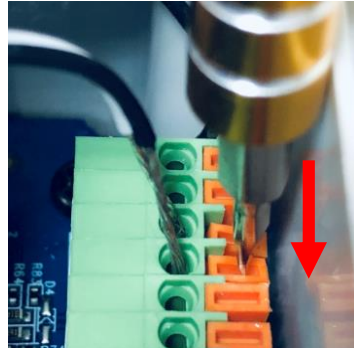
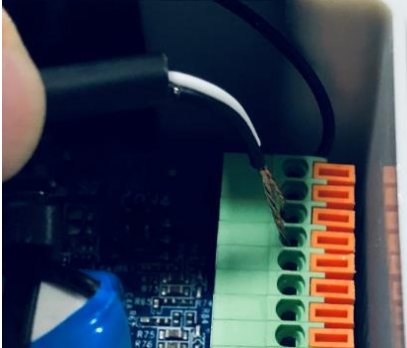

Screw back the External Parts of M16 Connector:

When you complete all the required hardware and software installation, make sure the device can function as planned. You are ready to lock the cables and external parts of the M16 connectors.

Step 1: a) Just keep required length of cable inside the enclosure; b) Insert the first cable gland part; c) Insert the second cable gland part; d) Insert the stopper if there is spare wire hole. Verify all the insert parts are in position.



Note:

1. Up to two cables can be run through the M16 connector. And to keep the IP65 water/dust-proof performance, all the cable gland parts and also the stopper are required to be installed properly.
2. However, if you intend to run more than two cables through the M16 connector, or IP65 is not so critical for the installation, you can decide not to put the cable glands, and skip step 1b) ~1d) for more IO flexibility.

Step 2: Place the last insert part of the M16 connector in position and fasten it in a clockwise direction. You have to hold the wire to prevent it twisting while fastening the M16 external part.

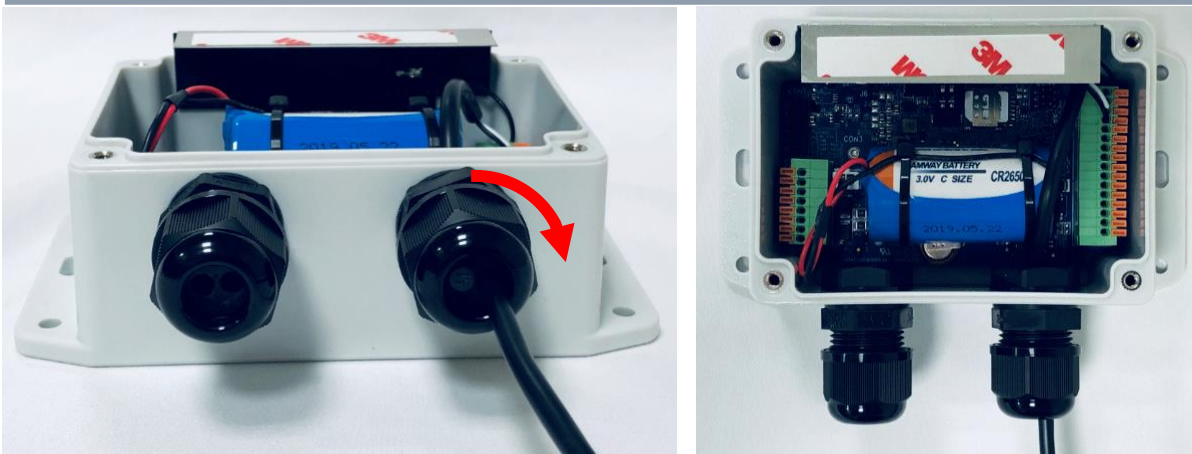

Connect to devices via AIs (Analog Input) :

The EDGE 2 provides 3 AI ports for connecting to analog sensor/meters. To connect the device, you have to identify the type of your device and properly connect and configure the EDGE 2 so that it can get the correct readings from the connected devices.

The AI port supports either 0-10V voltage mode, or 4-20mA current mode analog signal. Since the EDGE 2 cannot detect what kind of device it is connected to, not only hardware configuration (**CON4, CON5**) is required, but also software configuration is mandatory.

CON4 is dedicated for AI configuration. There are 3 sets of jumper headers, one for each AI port (AI1, AI2, AI3).

Without Jumper : **0-10V Voltage mode** - (factory default)

With Jumper : **4-20mA Current mode** - (You must put the Jumper manually)

Pinout Definition @ CON5

Pin1*	Pin2	Pin3	Pin4	Pin5	Pin6	Pin7	Pin8
3.6Vout1	GND	AI1+	AI1-	AI2+	AI2-	AI3+	AI3-

Note: 3.6Vout1 @ CON5.1 is only valid when external power source is applied. It is disabled for battery power source.

Analog Input Specification

Mode	Specification	
	Range	Precision
Voltage Mode	0-10V	+/- 10mV
Current Mode	4-20mA	+/- 20 μ A

The EDGE 2 is designed with 10-bit ADCs (Analog-to-Digital Converter), considering hardware scaling and 0.1% resistance variation effects, the overall precision for the 0-10V is around +/-10mV.

If the signal range of your device will run out off the design spec. of the EDGE 2 (0-10V or 4-20mA), you have to add a scaling circuit to prevent overflow readings and even damage to the EDGE 2.

Connect to devices via DIs / DO (Digital Input / Digital Output) :

The EDGE 2 provides 2 DI ports and 1 DO port⁴ for connecting to digital sensor/meter devices. To connect the device, you have to identify the type of device and properly connect and configure the EDGE 2 so that it can get the correct readings from the connected devices.

The DI port supports either Pulse counter mode, or just a Dry contact. Since the EDGE 2 cannot detect what kind of device it is connected to, not only hardware configuration (**CON5**) is required, but also software configuration is mandatory.

Pinout Definition @ CON5

Pin9	Pin10	Pin11	Pin12	Pin13	Pin14	Pin15	Pin16
DO+	DO-	DI1+	DI1-	GND	DI2+	DI2-	GND

Digital I/O Specification

I / O	Specification	
Digital Input	Trigger Voltage (high)	Logic level 1: 5V~30V
	Normal Voltage (low)	Logic level 0: 0V~2V
Digital Output	Non-Relay mode	Maximum 24V/300mA (Depends on external device)

Example of Connection Diagram

It is highly recommended to use 5-12 VDC power input instead of battery power if remote control function with Digital output is used for your IOT applications.

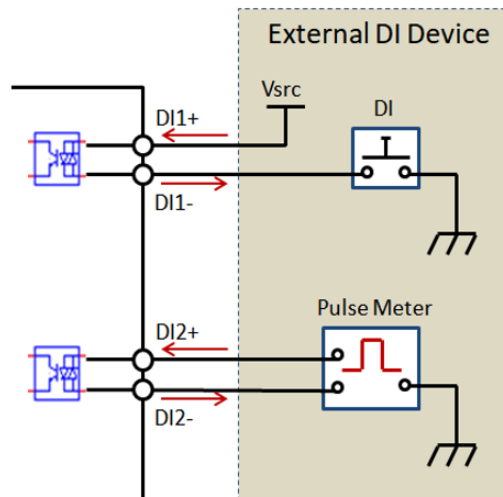

Example of Connection Diagram - DO

(1) Sink-type DO Connection

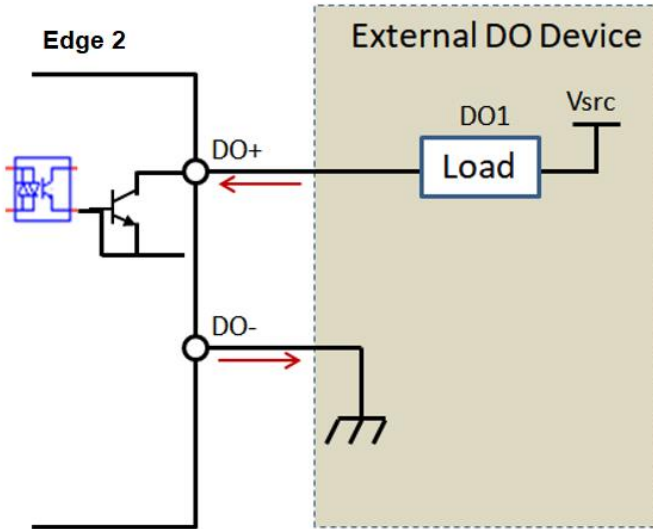

(2) Source-type DO Connection

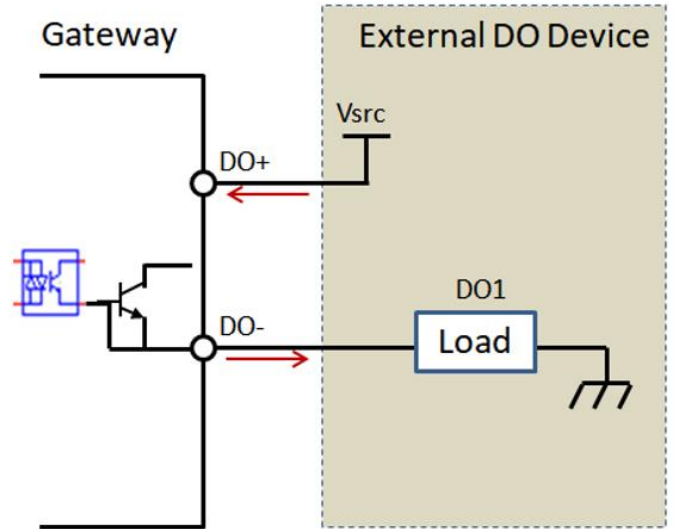

Connect to Modbus RTU devices via RS-485:

The EDGE 2 provides one RS-485 port and can support up to 3 cascaded Modbus RTU devices. Since the EDGE 2 cannot detect what kind of device it is connected to, not only hardware configuration (**CON2**) is required, but also software configuration is mandatory.

Pinout Definition @ CON2

Pin1	Pin2	Pin3	Pin4	Pin5	Pin6	Pin7	Pin8
GND	VDC (5-12V)	VDC (5-12V)	GND	RS-485 D- (A)	RS-485 D+ (B)	WakeUp-	WakeUp+

Connect to external magnetic switch via WakeUp port:

Most of the time, the EDGE 2 data logger operates under sleep mode with ultra low power consumption design. At that time, it will not wake up until the scheduled time runs out.

If you still have to wake it up for some unexpected reason, for example, to change software configuration or upgrade new firmware, there is a manual wake-up mechanism for such kind of maintenance situations.

There is an internal magnetic Reed Switch, located at the lower-left corner of the EDGE 2. Just take a small magnet and touch the lower-left corner of the enclosure, the EDGE 2 will detect it and enter into WakeUp state.

However, if the EDGE 2 is installed at a hard to reach location or enclosed in a metallic cabinet, there is an alternative option for you to easily wake up the EDGE 2. In such cases, you can connect an external magnetic switch or some kind of switch and connect it to the WakeUp pins. Once the input status changes (OPEN→CLOSE), the EDGE 2 will detect it and go into WakeUp state accordingly.

Pinout Definition @ CON2

Pin1	Pin2	Pin3	Pin4	Pin5	Pin6	Pin7	Pin8
GND	VDC (5-12V)	VDC (5-12V)	GND	RS485 D- (A)	RS485 D+ (B)	WakeUp-	WakeUp+

Connect to external DC Power Source:

The EDGE 2 is designed with internal Battery Power source. It is suitable for infrequent data logging or data uploading applications.

However, there is an alternative external DC Power Source for those applications that require instant or frequent data uploading. Instead of battery power source, you can decide to apply external DC power source to the EDGE 2 directly if there is available DC power source at the installation site.

Pinout Definition @ CON2

Pin1	Pin2	Pin3	Pin4	Pin5	Pin6	Pin7	Pin8
GND	VDC (5-12V)	VDC (5-12V)	GND	RS485 D- (A)	RS485 D+ (B)	WakeUp-	WakeUp+

External DC Power Supply: DC 5-12V
Max. Power: 5W @ 5V / 1A

Just connect the external DC Power to Pin1, Pin2 at **CON2**. PIN3, PIN4 are just duplicated pins, you can just ignore them.

Additionally, change the power source jumper to the right side (**EXT**) at **J6**, as illustrated below.



Note: The EDGE 2 won't go into sleep mode (ultra-low power consumption) when it is powered via external DC power source.

1.6.5 Connecting Console Port for PC Configuration Tool

After completing the prior hardware configuration, you are almost finished with the hardware configuration procedure.

To make the EDGE 2 operate properly in accordance with attached external devices, you have to further configure software settings from a PC configuration tool.

The EDGE 2 provides one serial console port for device configuration. You have to connect either USB-to-Serial console cable, or Bluetooth module⁵ to the Console Port at **CON1** as illustrated below.

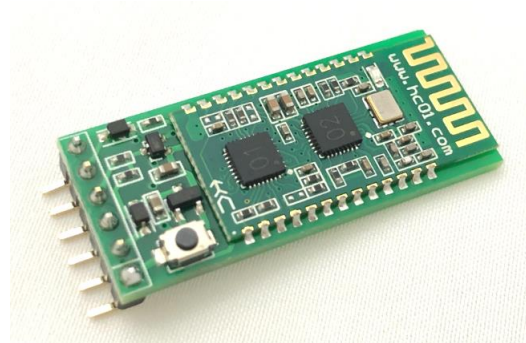

Pinout Definition @ CON1, USB-to-Serial, and Bluetooth Module

	Pin1	Pin2	Pin3	Pin4	Pin5	Pin6
CON1 @ EDGE 2	EN (O)	VCC (BT)	GND	UART RX(I)	UART TX(O)	BT State(I)
USB-to-Serial Cable	NC	NC	Black GND	White TX(O)	Green RX(I)	NC
Bluetooth Module	EN(I)	VCC	GND	TX(O)	RX(I)	BT State(O)

⁵ 5 Bluetooth modules are embedded for Edge Series. USB to Serial Console is an optional accessory.

Console port (CON1) with USB-to-Serial Console cable, or Bluetooth Module inserted.

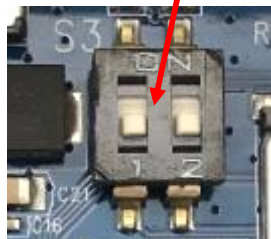
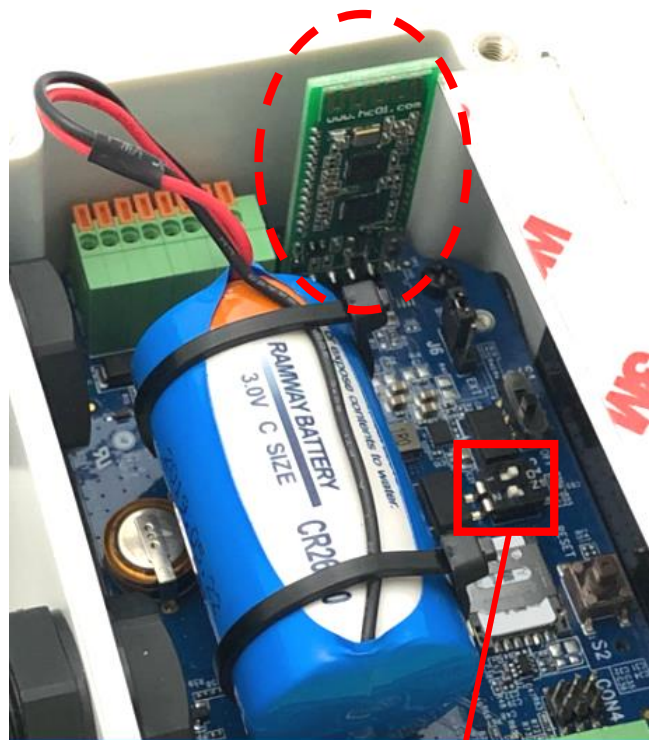

S3.1 OFF for wired configuration via console cable; **S3.1 ON** for wireless configuration via Bluetooth module.

EDGE 2

1.6.6 Power On the EDGE 2

Congratulations! You have just finished the required hardware installation procedure, and you are ready to power on the EDGE 2.

Please make sure the power source is properly installed:

For Battery Power: Battery power cable is plugged onto the Power Socket (CON3); and Power Source Jumper (J6) is placed at the left side (BAT).



For External DC Power: External DC power cable is inserted into the external DC Power Ports (CON2); and Power Source Jumper (J6) is placed at the right side (EXT).

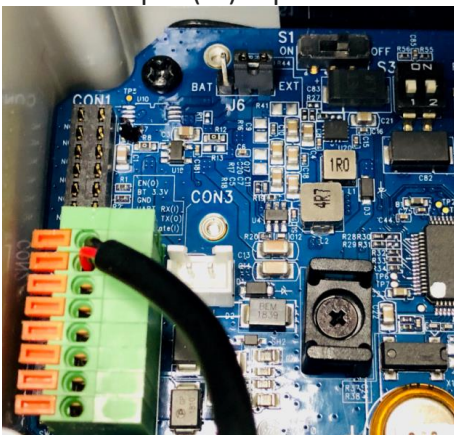

Now, just power on the EDGE 2 with Power Switch (S1). Switch it to the left side (ON) and the EDGE 2 is powered on and will start to boot up.



Then you can check the Status LED. It starts with RED light for a few seconds to connect with the LPWA network. After a while, it will turn to BLUE light when it is connected to the LPWA network without problem, or you will see the LED flashing with RED light indicating low battery power level or no SIM detected.

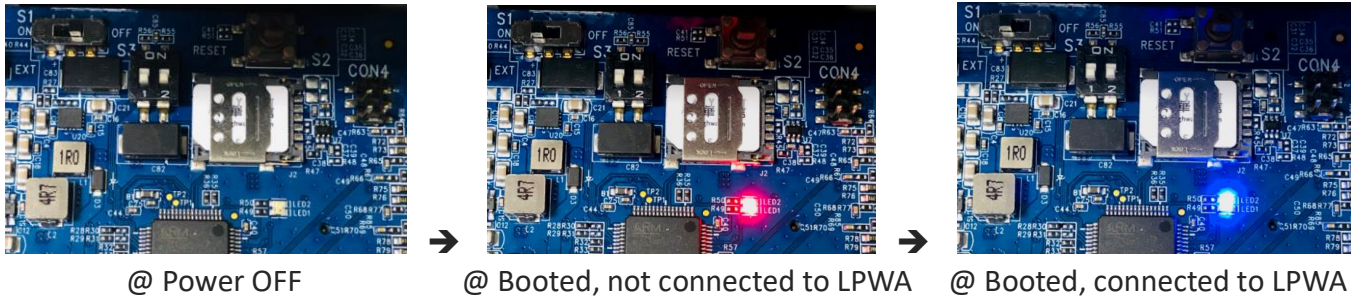

Note: If the Data Logger is powered with battery source, the LED will be forced to OFF state when the device goes into sleep mode.

Configuration steps via Bluetooth

1. Power on the EDGE 2
2. Turn on Bluetooth function of Laptop to run SCAN. Select model name of “EDGE 2” in the scan results for connection. The default PIN is 1234.
3. Once a BlueTooth connection is established successfully, the corresponding COM interface will display on the connecting computer. Open the Edge Series configuration tool to map the COM port in order to proceed with the configuration. In order to save power, remove the Bluetooth module after configuration is complete. If you need to keep the Bluetooth module installed for configuration in the device, use 5-12VDC power instead of battery power.

6 Use 5-12VDC power instead of battery power if the Bluetooth module is to remain in the device.

1.6.7 Setup with Windows-based Configuration Tool

The EDGE 2 must be configured with a Windows configuration tool. Just find a computer with an available USB port, and plug in the USB-to-Serial console cable; You can also use a Bluetooth enabled laptop to configure the EDGE 2 wirelessly.

For the first time to set up the EDGE 2 with this Configuration Tool, you must download it, and install it to the local computer for further device configuration.

When you execute the Configuration Tool, you will see the login dialog. Click the drop-down menu next to the “Serial Port”. Choose the COM port that is bound to the EDGE 2 console port, and then click the **Connect** button.

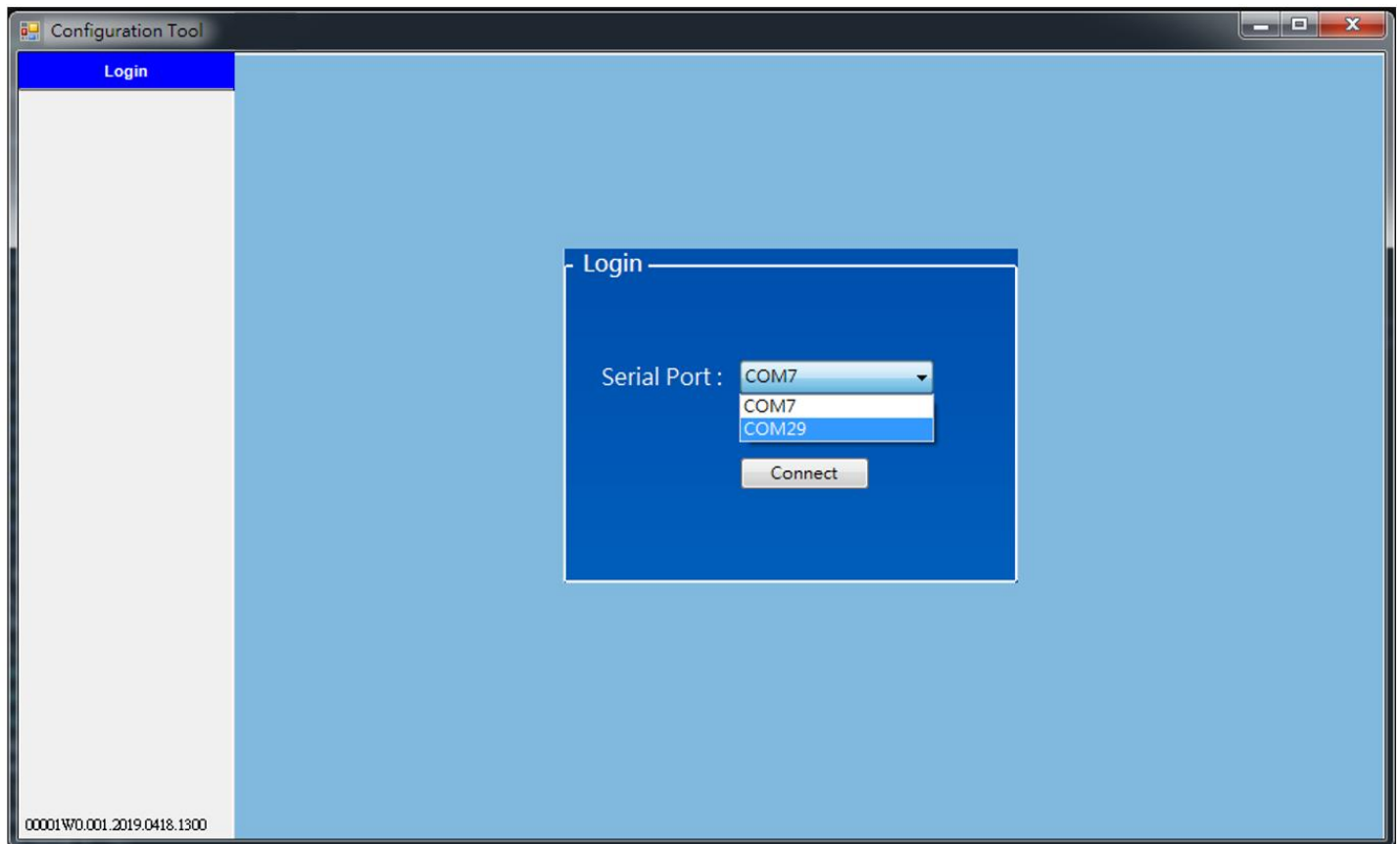

Note:

1. Use external DC power source to power on the data logger while configuring via the Windows Configuration Tool. With DC power source, the device won't go into sleep mode, so you can configure it without time and power consumption considerations.
2. Or, if DC power source is not available at the installation site, it is suggested to **configure the device with a prepared configuration file to prevent unexpected battery power loss**. Restore the prepared configuration file, and quickly edit the settings unique to the certain device. In order to save power, remove the Bluetooth module after configuration is complete.

If the connection succeeds, a list of menu items appears on the left side under the Login Tab.

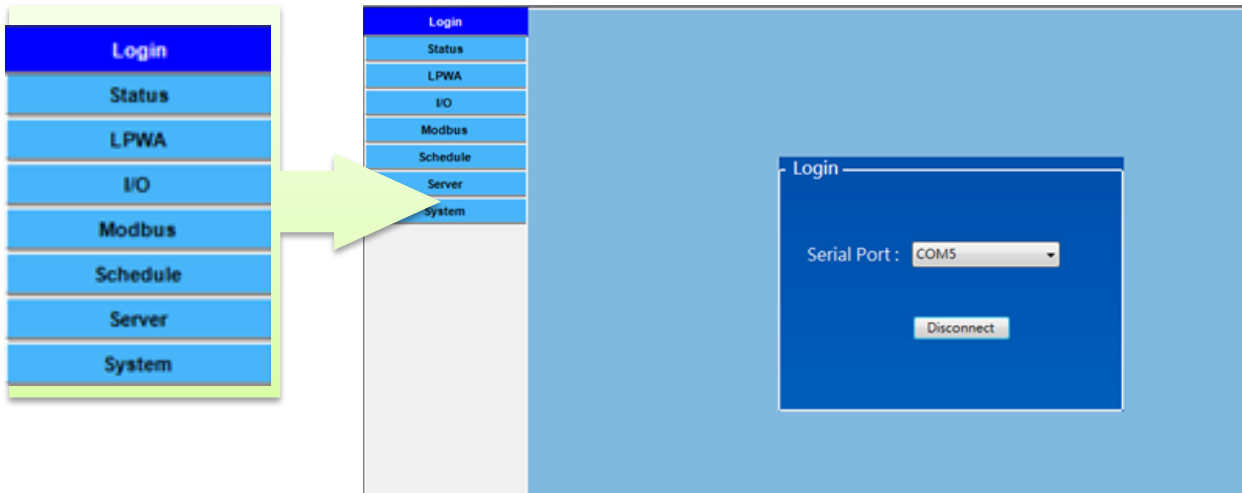

Now you already logged in to the EDGE 2 console, and you can proceed with the required software configuration steps one by one. Refer to the following chapter for details.

1.6.8 Device Mount and Screw Back the Top Cover

After you finished all the software configurations, you are ready to use the EDGE 2 and make it operate as expected. You must take the following actions:

1. **Power off the EDGE 2, and remove the console cable / Bluetooth module.**
2. **Mount the EDGE 2 base enclosure on the planned location.**
3. **Make sure all the wiring cables are running in position through the M16 connectors.**
4. **Tightly fasten the external parts on the M16 connectors, holding the internal cables to prevent them from twisting along with the cable gland.**
5. **Power on the EDGE 2, and wait until the Status LED turns BLUE to make sure it is connected to an LPWA network.**
6. **Screw back the top cover with care. Make sure the surrounding rubber pad is fully in position to keep the IP65 performance for water and dust resistance.**

Chapter 2 Device Configuration

2.1 Device Status

Click on **Status** menu item, and the EDGE 2 device information and status will display on the configuration area which is located in the right-hand side. If the device status doesn't appear or you want to get the updated status, click the **Status Refresh** button located at the lower right corner to refresh the status immediately.

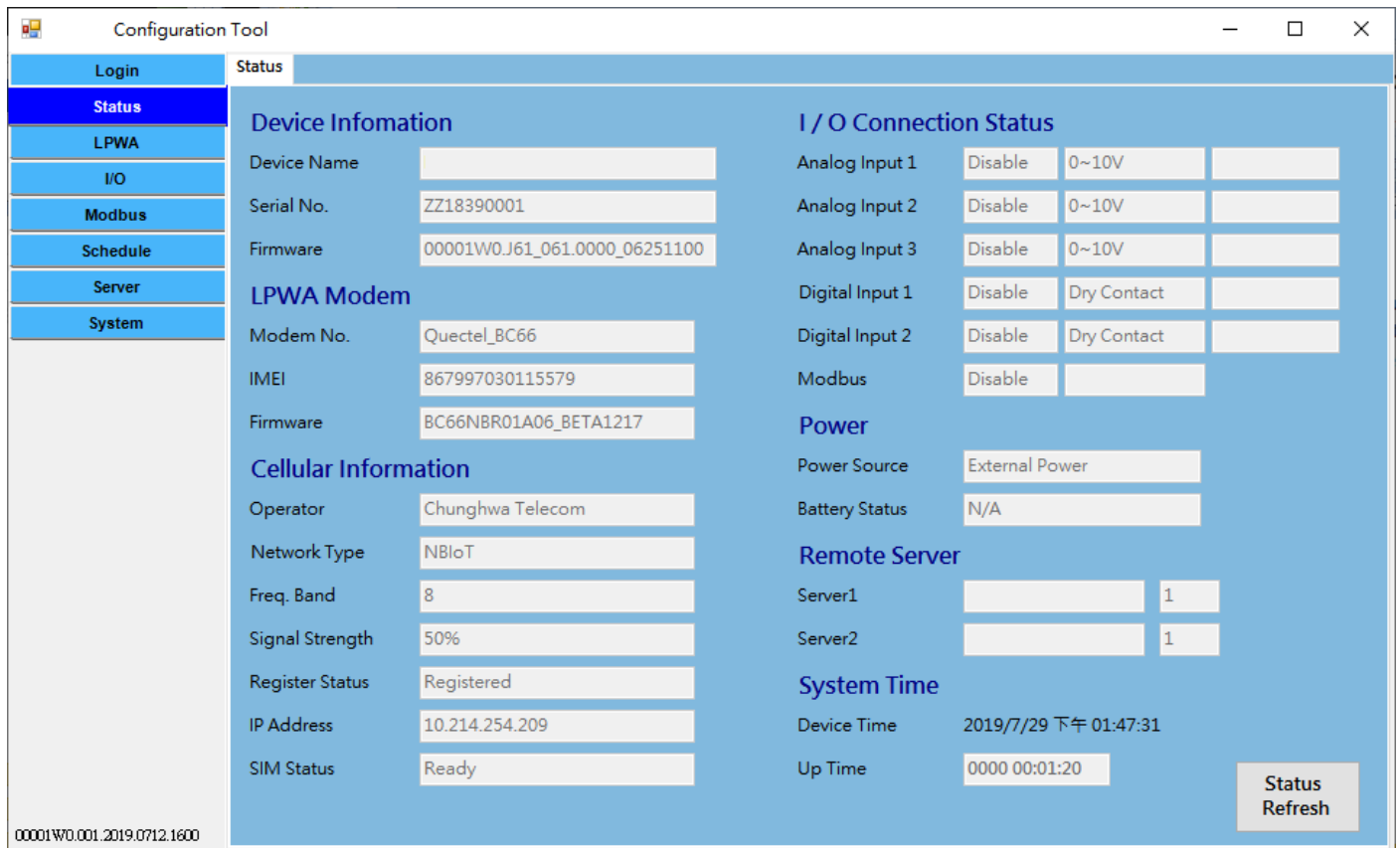

You can see the **Device Information** (Device Name, Series No., and Firmware Version), **LPWA Modem** Information (Modem No., IMEI, and Modem Firmware), **Cellular Information** (Operator, Network Type, Freq. Band, Signal Strength, Register Status, IP Address, and SIM Status), **I/O Connection Status** (Analog Input 1~3, Digital Input 1~2, and Modbus), **Power** Information (Power Source, and Battery Status), **Remote Server** Settings and **System Time**.

2.2 LPWA Configuration

With SIM card inserted in the SIM socket, you need to enter the required **APN**, optional **Username / Password**, and select the **Network Type** (Cat M1 or NB-IoT) for the LPWA connection. Then click **Save** button to store the settings in the device.

Login	
Status	
LPWA	
I/O	
Modbus	
Schedule	
Server	
System	

LPWA Connection

APN (required)

Username (optional)

Password (optional)

Network Type

These configuration settings shall be provided with the SIM card by the ISP of the LPWA network.

You can check the cellular information on the **Status** page to understand the LPWA connection status. With it, you will know if the SIM card is inserted or not, whether the device is connected to LPWA network or not, and even the LPWA signal strength (%) at the installation site of the data logger.

Cellular Information	
Operator	Chunghwa Telecom
Network Type	NB-IoT
Freq. Band	8
Signal Strength	57%
Register Status	Registered
IP Address	10.208.204.207
SIM Status	Ready

2.3 I/O Configuration

On the I/O Configuration screen, you can configure the Analog Inputs (AIs) and Digital Inputs (DIs). There are 3 sets of AIs and 2 sets of DIs.

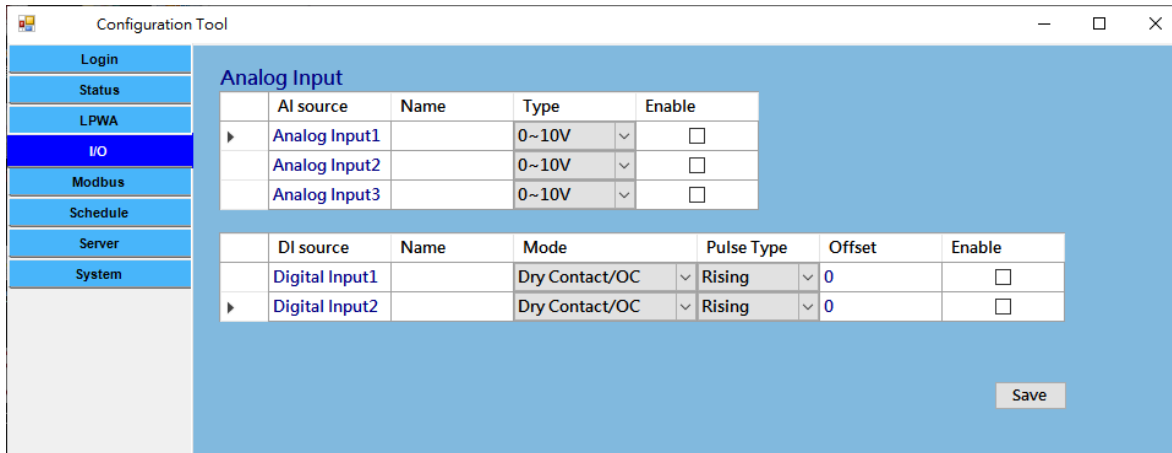

According to the hardware configuration you already finished, you have to further configure the settings for the device firmware, so that the data logger will know what kind of input device is connected to each port.

For analog input ports, you can specify an optional **Name** for identification, and the **type (0-10V, or 4-20mA)** for each connected port. Then click **Enable** check boxes for those connected ports.

For digital input ports, you can specify an optional **Name** for identification, and the **Mode (Dry Contact, or Pulse Counter)** for each connected port. And then click **Enable** check boxes for those connected ports.

If **Pulse Counter** mode is selected, some additional fields (**pulse type** and **Offset** value) have to be defined.

Pulse Type: It can be **Change, Rising, or Falling**. On each pulse event, the corresponding internal counter will be increased by 1 automatically.

Offset: Enter the Offset value for initial reading of the connected device (pulse meter). It is very likely that the initial reading for the connected device is a non-zero value, so you have to enter the initial value as an offset for the further readings.

With the settings, the Data Logger will activate 32-bit counters to count the pulse behavior, record the counter value plus the Offset as the actual value on each data logging time slot.

Finally, click **Save** button to store the configuration in the device. Prior to storing the I/O settings, the following dialog will appear for you to double confirm the settings of Analog Input type that the hardware configuration and software configuration are consistent.

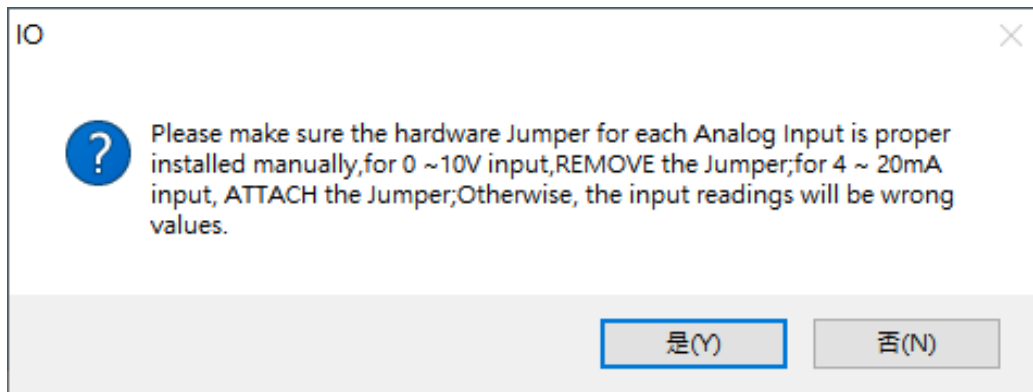

After you confirm the settings are correct, click **Yes** button to store the configuration in the device.

For models with battery power options, there is a Battery Threshold configuration. You can define the Battery Full and Battery Low voltage.

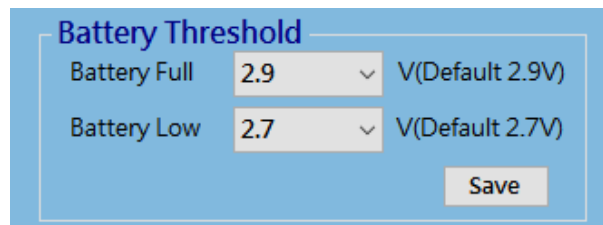

You can check the battery status at the Status Page.

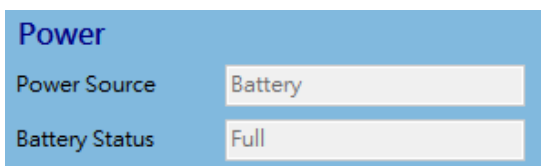

- Full:** for voltage \geq Battery Full threshold.
- Good:** for voltage between Battery Full and Low thresholds.
- Low:** for voltage \leq Battery Low threshold.

The data logger will issue Battery Low event to remote server if it detects the battery voltage approaches the Low threshold. The frequency depends on the Remote Server Schedule rule.

Each time when the data logger is woken up to send the stored log to remote server, if the Battery Low threshold is triggered, the data logger will automatically issue a Battery Low event.

So, when the administrator notices that Battery Low events are issued, he should dispatch battery replacement task prior to the data logger using up the battery power and failing to operate properly.

2.4 Modbus Configuration

The EDGE 2 provides one RS-485 port for connecting with Modbus RTU Slave devices. It can handle up to three sets of cascaded Modbus devices.

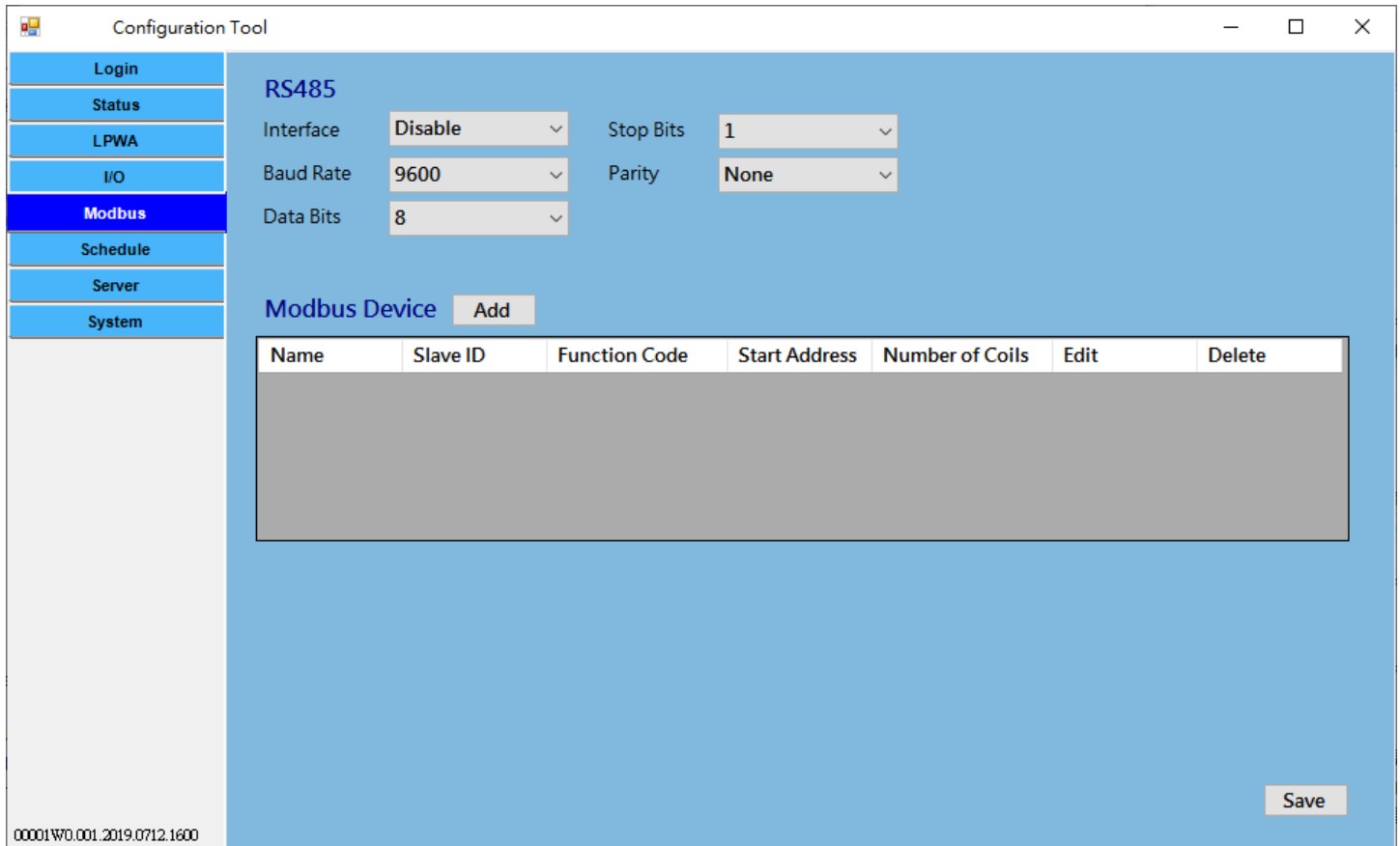

RS-485 Serial Port Configuration

Prior to configuring how to access the Modbus devices, you need to define the physical communication port first. In RS-485 configuration, you can enable the **Interface**, and then select desired values for **Baud Rate**, **Data Bits**, **Stop Bits**, and **Parity** settings.

- Interface:** By default, the interface is disabled. You can enable it and set the interface parameter to comply with the devices to be connected.
- Baud Rate:** Select the appropriate baud rate for serial device communication. It can be 1200 / 2400 / 4800 / 9600 / 19200 / 38400 / 57600 / 115200. It depends on the cable length and the installed environment. The longer cable length will result in lower baud rate for it. By default, 9600 is selected.
- Data Bits:** Select 7 or 8 for data bits. 8 is selected by default.
- Stop Bits:** Select 1 or 2 for data bits. 1 is selected by default.
- Parity:** Select None / Even / Odd for Parity bit. None is selected by default.

Modbus Device Configuration

Click **Add** button to enter required information or values for each Modbus device. The data fields are **Name**, **Slave ID**, **Function Code**, **Start Address**, and **No. of Coils/Registers**. When you entered the required settings for a Modbus device, click **Confirm** button to update the information to the device list. In addition, you can also click **Edit** or **Delete** button to modify the information or values in the device list.

The screenshot shows a web interface for configuring a Modbus device. At the top left, there is a header "Modbus Device" and an "Add" button. Below this is a table with the following columns: Name, Slave ID, Function Code, Start Address, Number of Coils, Edit, and Delete. The table is currently empty. Below the table, there are several input fields: "Name" with a text box, "Slave ID" with a text box and a range "(1-247)", "Function Code" with a dropdown menu showing "Read Coils (0x01)", "Start Address" with a text box and a range "(0-65535)", and "Number of Coils" with a text box and a range "(1-2000)". At the bottom right, there are three buttons: "Confirm", "Cancel", and "Save".

Name: Enter a name as the identifier of the Modbus RTU slave device.

Slave ID: Specify a unique ID for the slave device. It can be 1 - 247.

Function Code: Specify a certain read function for the Data Logger to issue and record the responses from slave device. It can be **Read Coils (0x01)**, **Read Discrete Input (0x02)**, **Read Holding Registers (0x03)**, and **Read Input Registers (0x04)**.

Start Address: Enter the Start Address of registers to apply with the specified function code. It can be 0 - 65535.

No. of Coils/Registers: Enter the number of coils (registers) to apply with the specified function code. It can be 1 - 125.

Check the documentation for the connected Modbus devices on how to get the desired data through Modbus commands.

Finally, click **Save** button to store the configuration in the device.

2.5 Schedule Configuration

The major function of the EDGE 2 Data Logger is to record the status of connected devices at pre-defined time intervals, and upload the stored data logs to remote server at another designated time interval. All these actions are guided by a set of schedule rules.

In the **Schedule** Configuration page, you have to define the required schedule rules for the application being deployed. For example, record the status of AI / DI ports once per hour, record the status of Modbus devices once per day, and upload the pending logs to remote server on every Monday 02:00a.m..

The EDGE 2 Data Logger provides different types of time options for defining the time interval or frequency as time schedule. Set up your planned schedule and the Data Logger will take appropriate action accordingly by schedule rule.

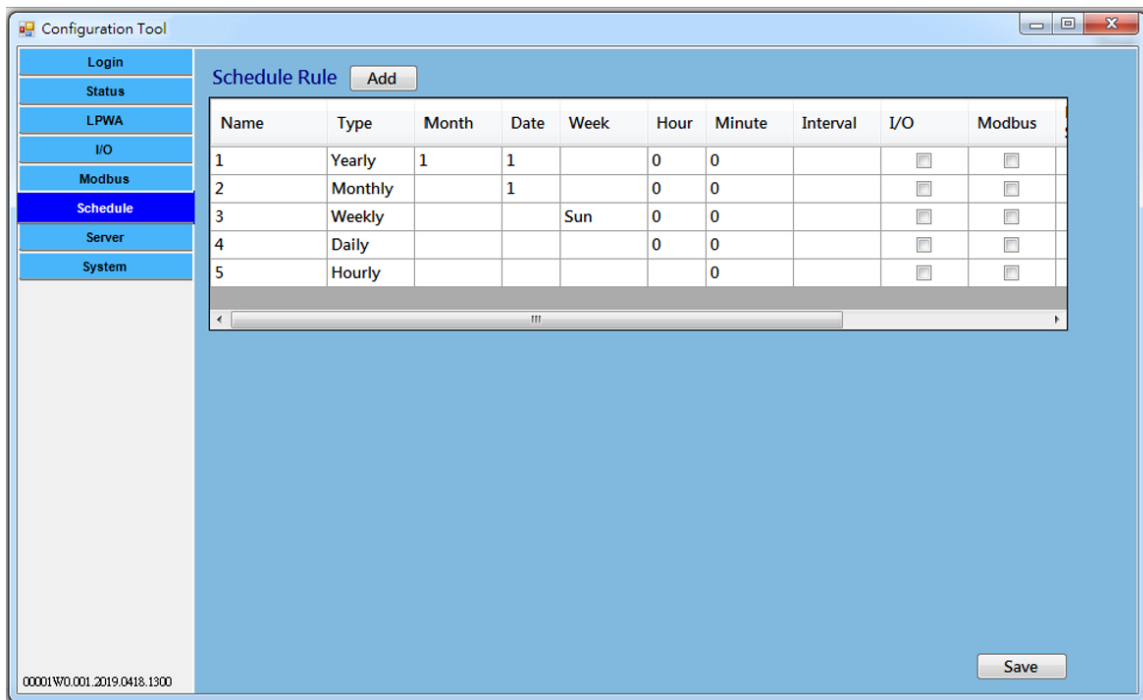

Click the **Add** button to enter required settings for a new schedule rule. The data fields are **Name**, **Type**, **Time** (Month, Date, Week, Hour, Minute, and Interval), **I/O**, **Modbus**, and **Remote Server**. When you have entered the required settings, click **Confirm** button to update the information to the rule list. In addition, you can also click **Edit** or **Delete** button to modify the settings in the rule list.

Name: Specify a name as the identifier of the Modbus RTU slave device.

Type: Select the schedule type for the data logger to take action. There are two groups of types for your preference.

Group 1 consists of **Yearly, Monthly, Weekly, Daily, and Hourly**. You select a time period, and the data logger will be triggered once to take action (data logging, or uploading) for each selected period.

Group 2 consists of **per Minutes, per Hours, and per Days**. You select a time base, and the data logger will be triggered on each expected time interval to take action (data logging, or uploading).

Time: In conjunction with the schedule type you selected, you have to further specify a precise time (date, and/or time), or a time interval for the time scheduler to count the time.

Function: Click on the checkbox to select expected action(s) to take for the schedule rule. It can be **I/O**, and/or **Modbus** for a data logging rule; or **Server** for a data uploading rule.

Finally, click **Save** button to store the configuration in the device.

Hereunder are more description and examples for the different schedule types:

Yearly Triggered at a fixed time in each year. For example, when Month=1, Date=1, Hour=1, Minute=1, the schedule rule will be triggered at 1/1 01:01 every year.

Monthly Triggered at a fixed time in each month. For example, when Date=1, Hour=1, Minute=1, the schedule rule will be triggered at 01:01 on the 1st day in every month.

Weekly every Sunday.

Daily Triggered at a fixed time in a day. For example, when Hour=1, Minute=1, the schedule rule will be triggered at 01:01 every day.

H Triggered at a fixed time in an hour. For example, when Minute=15, the schedule rule will be triggered at
ou the 15th minute every hour.
rl

Pe Triggered at a fixed interval per minutes. For example, when Start=12:00, Interval=5, the scheduled
r , 12:15, and so on. The minimum interval of “Per Minutes” to place is **5** and the maximum is **7200**.

Mi
nu
te
s

Pe Triggered at a fixed interval per hours. For example, when Start =12:00, Interval =2, the scheduled
r function will start at 14:00, 16:00, 18:00, and so on. The minimum interval of “Per Hours” to place is **1** and
H the maximum is **23**.

ou
rs

Pe Triggered at a fixed interval per days. For example, when Start=12:00, Interval=1, the scheduled function
r will start at 01/01 12:00, 01/02 12:00, 01/03 12:00, and so on. The minimum interval of “Per Days” to
Da place is **1** and the maximum is **6**.

ys

2.6 Server Configuration

The EDGE 2 Data Logger is designed to collect field device status / readings, store in embedded non-volatile memory in according to the specified time period, and then upload the collected data to remote server, via LPWA connection, for further processing and analysis by schedule.

So, you have to specify where the remote server is, and how to communicate with the server. The EDGE 2 supports two sets of remote servers, and three protocols (UDP, TCP, and MQTT) for communicating with the server(s).

There are some situations that the administrator at remote control center would like to send commands to the Data Logger for specific actions. The Data Logger provides such downlink communication, realized with MQTT subscription. You can specify a MQTT server (Broker) and the message topic to subscribe.

Once the Data logger is woken up on remote server schedule rule, it will get the pending commands queued in the server, and then take the corresponding action consequently.

Remote Server Configuration

The Data Logger packs the logged data with specified protocol with required packet headers, and then sends out complete packets to remote server. To retrieve the data logs sent to remote server, the server has to run a simple daemon to collect the packets sent from deployed data loggers, and interpret the data fields for mapping to each field device.

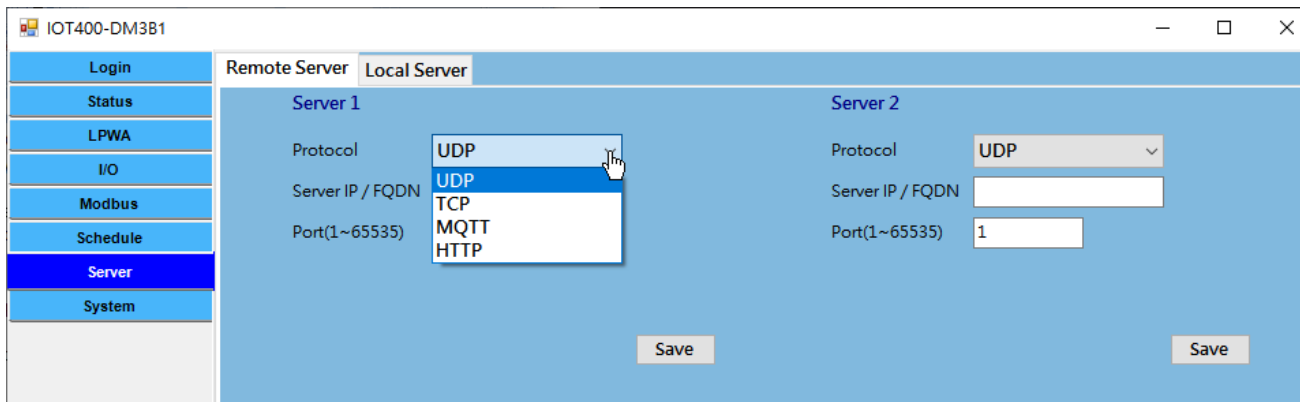

To finish the **Server** Configuration, you have to specify the following settings:

Protocol: Select a communication protocol for the drop down list. It can be **UDP**, **TCP**, **MQTT** or **HTTP**.

Server IP/FQDN: Enter the global IP address or FQDN of the remote server, or MQTT broker. Leave it as blank to disable the corresponding server settings.
It is set as blank by default.

Port (1~65535): Enter the port number used to communicate with deployed Data Loggers.

Finally, click **Save** button to store the configuration in the device.

Additional MQTT Settings

When **MQTT** protocol is selected, additional settings will appear on the screen. Enter the required information for **Username**, **Password**, **Client ID**, **Event Topic**, and **Data Topic**, set the **QoS Level** and **Retain** settings.

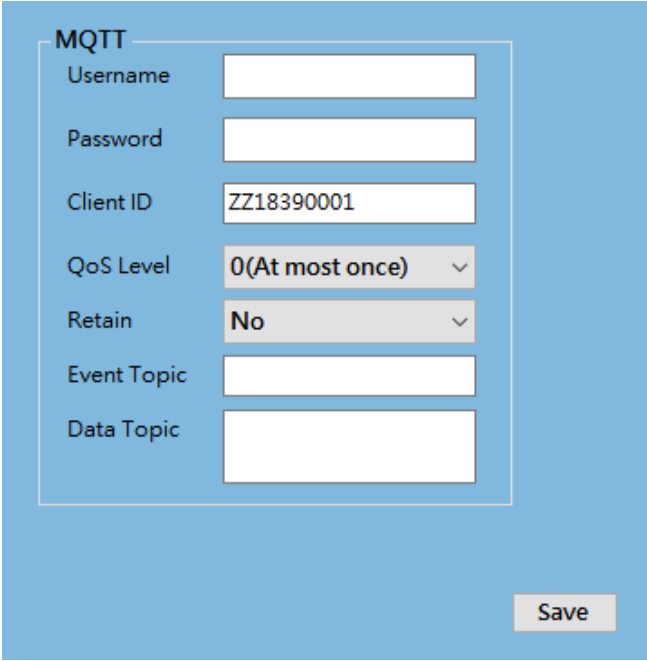

The screenshot shows a configuration window for MQTT settings. The window has a light blue background and a white border. At the top left, the title 'MQTT' is displayed. Below the title, there are seven rows of input fields and dropdown menus. The first row is 'Username' with an empty text box. The second row is 'Password' with an empty text box. The third row is 'Client ID' with a text box containing 'ZZ18390001'. The fourth row is 'QoS Level' with a dropdown menu showing '0 (At most once)'. The fifth row is 'Retain' with a dropdown menu showing 'No'. The sixth row is 'Event Topic' with an empty text box. The seventh row is 'Data Topic' with an empty text box. At the bottom right of the window, there is a 'Save' button.

- Username:** Enter optional username (account) given by MQTT Broker, if authentication is required.
- Password:** Enter optional password given by MQTT Broker, if authentication is required.
- Client ID:** Specify a unique ID for the data logger. It can be the Serial No. of the data logger. The default ID is set to the device Serial No.
- QoS Level:** Select the QoS type for publishing a message. For the LPWA data logger, 0 (At most once) is preferred to keep its low power consumption performance.
- 0 (At most once):** the message will be published only once, and the broker and subscribed client(s) take no additional steps to acknowledge the delivery.
- 1 (At least once):** the message will be published at least once until acknowledgement is received from the broker or subscribed client(s).
- 2 (Exactly once):** the message will be published to subscriber(s) once in a two-level handshake to ensure only one copy of the message is received.
- Retain:** Select the Retain policy, **Yes** or **No**, for publishing a message. By default, **No** is selected.
- Event Topic:** Specify the topic name for the system-related message. The messages for LPWA status and Battery Low belong to the event message, and are helpful for device management.
- Data Topic:** Specify the topic name for the data logging message. The messages for AI/DI data and Modbus data belong to this topic. Up to 64 characters for the topic name.

Event and Data topics provide a simple way for message classification. However, you can also decide to specify the same name for both topics.

Local Server Configuration

You can activate the Local Server function to get the downlink commands and take corresponding actions. Currently, **OTA FW Upgrade** and **DO Control** are supported. You can select the command type and then configure the details.

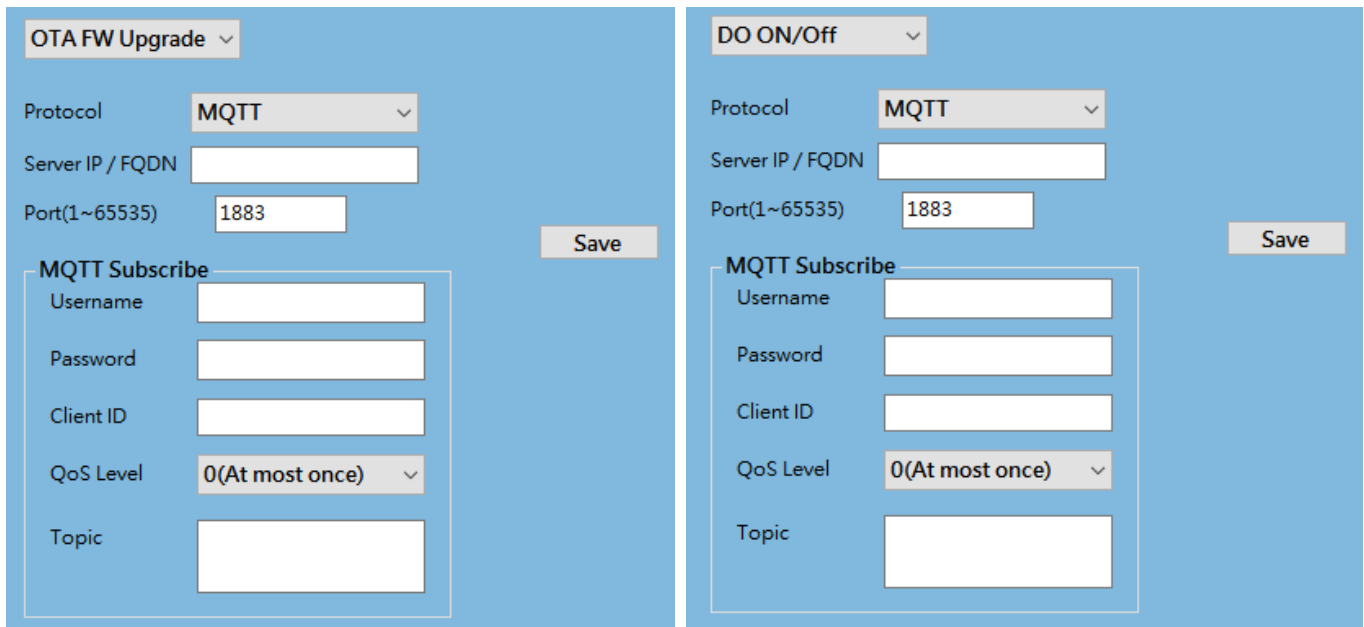
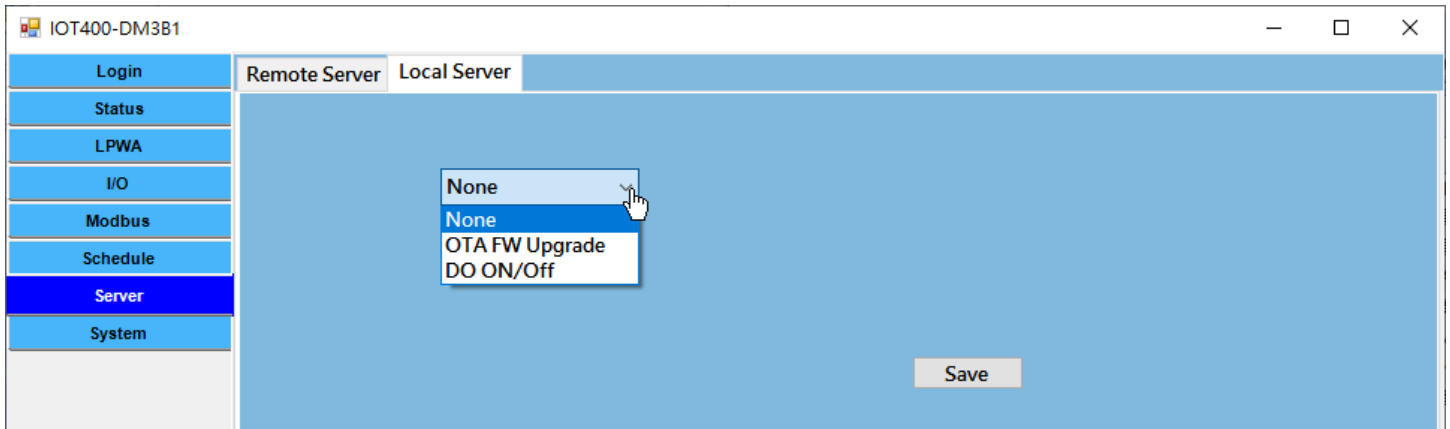

First, select the command type, and then configure the MQTT-related settings (**Server IP/FQDN**, **Port**, **Username**, **Password**, **Client ID**, **QoS Level** and **Topic**).

Server IP/FQDN: Enter the global IP address or FQDN of the MQTT server or MQTT broker.
It is set as blank by default.

Port (1~65535): Enter the port number used by the MQTT server.

Username: Enter optional username (account) given by MQTT Broker, if authentication is required.

- Password:** Enter optional password given by MQTT Broker, if authentication is required.
- Client ID:** Specify a unique ID for the data logger. It can be the Serial No. of the data logger. The default ID is set to the device Serial No.
- QoS Level:** Select the QoS type for publishing a message. For the downlink communication with LPWA data logger, 2 (Exactly once) is preferred to make sure the data loggers won't miss the commands issued from remote control center.
- 0 (At most once):** the message will be published only once, and the broker and subscribed client(s) take no additional steps to acknowledge the delivery.
- 1 (At least once):** the message will be published at least once until acknowledgement is received from the broker or subscribed client(s).
- 2 (Exactly once):** the message will be published to subscriber(s) once in a two-level handshake to ensure only one copy of the message is received.
- Topic :** Specify the topic name for the corresponding downlink command. The messages for LPWA status and Battery Low belong to the event message, it is helpful for device management.
- For example, ***FW_OTA*** as the topic of OTA FW Upgrade command, and ***DO_Setting*** as the topic of DO control command.

As to the details about command format, you can refer to **Section 3.2 Downlink Command Format**.

2.7 System Configuration

System Configuration allows the device administrator / installer to manage the Data Logger. There are settings / function buttons for **Reboot**, **Reset to Default**, **Configuration Backup / Restore**, **System Log**, **Firmware Upgrade**, **System Time**, and **Wake-up Trigger**.

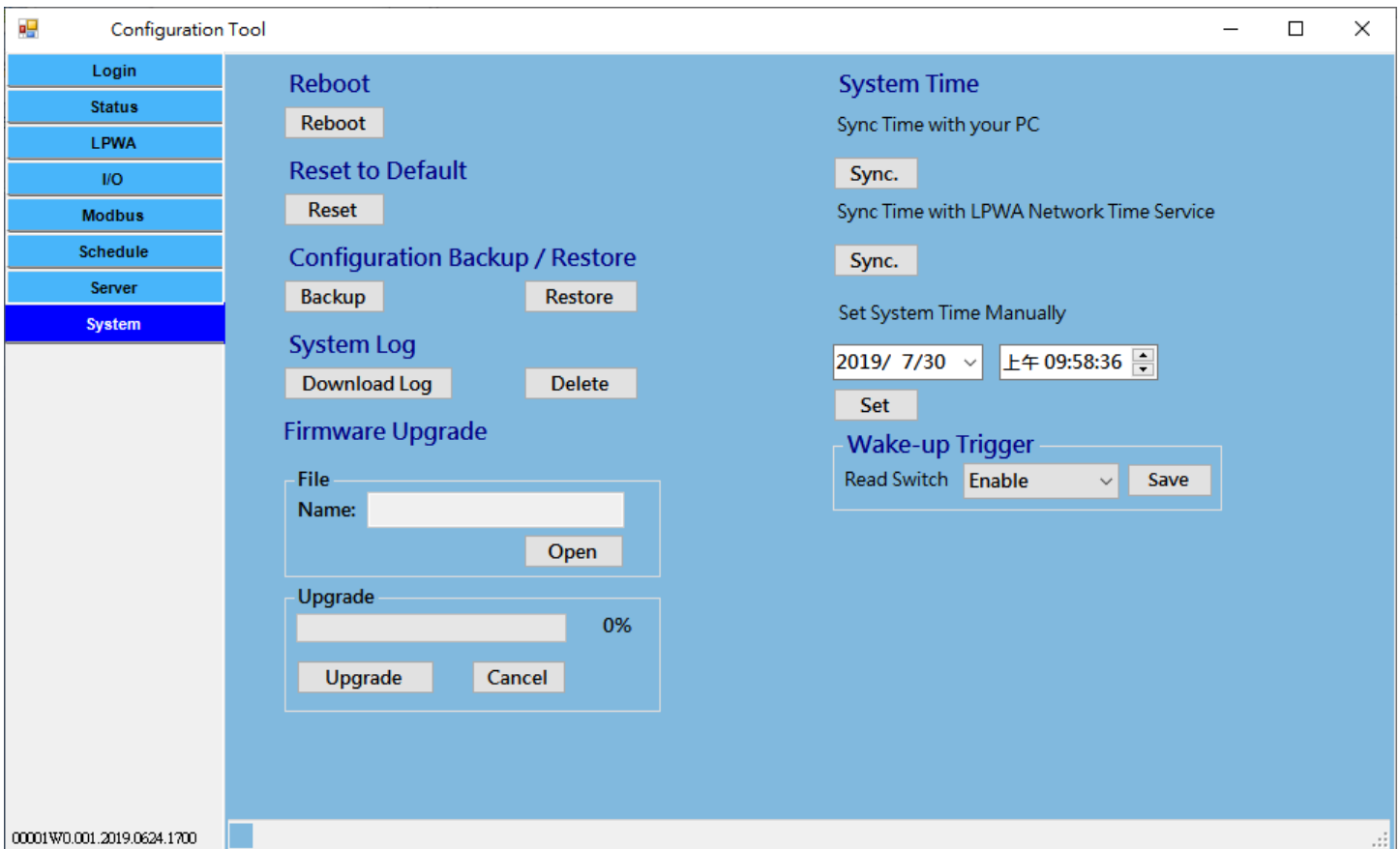

Reboot or Reset to Default

For some special reason or situation, you may need to reboot the Data Logger or reset the device configuration to its default value.

Click **Reboot** or **Reset** button, and wait a while for the device to reboot.

Configuration Backup / Restore

In addition to the factory default settings, you can also customize a special configuration setting as a customized default value. With this customized default value, you can reset the device to the expected default setting if needed.

Click **Backup** button to store the device configuration settings into a configuration file (.bin) for later use.

Click **Restore** button to restore the device settings to a certain backup copy, or quickly duplicate a device's configuration file to other devices with the same configuration for a certain application. In such case, be sure to set the unique Device ID for separate devices.

System Log

For some device maintenance purposes, you may need to get the system log for troubleshooting. You can do it through the configuration tool, click **Download Log** or **Delete** button.

Click **Download Log** button to store the System Log into a log file (.txt) for troubleshooting.

Click **Delete** button to erase the existing system logs. Please use the delete function with care, all the device system log, including data log, will be erased. If required, download log first and then delete out-of-date log.

Firmware Upgrade

If new firmware is available, you can manually upgrade it for feature enhancement or bug resolving.

Click **Open** button to identify the file location / file name of the new firmware image (.bin).

Click **Upgrade** button to start upgrading the new firmware to the device. DO NOT turn off the Data Logger, or disconnect the console cable while upgrading new firmware, it is very likely to damage the device.

Once the Firmware Upgrade completed, the device will be reboot with the new firmware immediately.

System Time

System time is a vital element for the Data Logger. Both data logging and data uploading tasks need to be triggered at a certain time. You have to make sure the Data Logger is configured with correct time settings.

There are three approaches for initial settings. You can simply click **Sync** button to synchronize the Data Logger's time with your PC that is running the configuration tool, or synchronize it with the LPWA network time service. You can also set the date and time for the Data Logger manually.

Wake-Up Trigger

Most of the time, the EDGE 2 data logger operates under sleep mode with ultra low power consumption design. At that time, no one can wake it until the scheduled time.

However, there is a manual Wake-Up Trigger mechanism for you to wake up the data logger for some unexpected reason, for example, to change software configuration or upgrade new firmware.

By default the Reed Switch Wake-Up Trigger is enabled. The Reed Switch is located at the lower-left corner of the EDGE 2. You can just take a small magnet and touch the lower-left corner of the enclosure, the device will detect it and get into WakeUp state.

Chapter 3 Data and Command Formats

According to the defined schedule rules, the Data Logger will log the status of the connected devices (AIs, DIs, and Modbus) in non-volatile storage, and upload those pending logs to specified remote server(s).

When the remote server (UDP / TCP / MQTT protocols) receives the packets of data logs, it can easily get the payload, interpret the data fields, and then import the data to the application database for further processing.

The administrator can issue downlink commands via MQTT message from the control center for controlling the deployed data loggers. For example, OTA firmware upgrade, or change DO status to turn ON/OFF for a specific connected device.

3.1 Data Log Format

Each data log entry is composed with a formatted string, followed with CR / LF characters.

```
SerialNo  DateTime  LogType:Data
```

SerialNo :	Serial no. for the device that sent the data log.
DateTime:	The recorded time for the following data log.
LogType:	The type of the following data. It can be IO , M1 , M2 , and M3 . Each log type will be follow with different data format. There are some non-data LogType event logs for management purposes. It can be EB (Battery Low), EN (Uplink Network), EP (Power ON), and EW (Device WakeUp).
Data:	The actual data for the corresponding type of device.

Data Format of IO:

```
IO:TypeVal1,TypeVal2,TypeVal3,TypeVal4,TypeVal5
```

The Data Logger provides five Input ports. Each time the IO schedule rule triggered, the port type and status for all the five ports will be recorded as the data log simultaneously in an IO record.

TypeVal1~5 :	One character for the type, V for 0-10V Voltage mode; A for 4-20mA Current mode; D for Dry Contact; and P for Pulse Counter. Followed by a value for each port. A certain TypeVal will be skipped if it is a disabled port.
---------------------	---

For examples,

“IO:V1.10,A12.50,V3.30,D1,P1234” stands for a log entry from Input ports, where Port A1 is 1.10Volt, A2 is 12.50mA, A3 is 3.3Volt, D1 is at ‘1’ for HIGH, D2 counter reading is 1234.

“IO:V1.10,,,D0,” stands for a log entry from Input ports, where Port A1 is 1.10Volt, D1 is at ‘0’ for LOW. In this case, AI2, AI3, and D2 are missing because they are disabled.

Data Format of M1, M2, M3:

M1:ID,FC,ADDR,LEN:Val

M2:ID,FC,ADDR,LEN:Val

M3:ID,FC,ADDR,LEN:Val

The Data Logger supports up to three Modbus RTU devices. Each time the Modbus schedule rule triggered, the specified device status will be recorded as the data log in individual M1/M2/M3 record sequentially.

ID :	The Modbus ID for the corresponding Modbus device.
FC :	The function code issued to get the Modbus data.
ADDR :	The start address for getting the Modbus data.
LEN :	The no. of coils/registers for getting the Modbus data.
Val :	The recorded Modbus data that is retrieved with specified command.

For examples,

“M1:1,1,0,32:01020304” stands for it is a log entry from the first Modbus device, where Modbus ID is 1, Function Code is 1, Start address is 0, no. of Coils is 32(bits), data string is 01020304.

“M2:2,2,1,1:00” stands for it is a log entry from the second Modbus device, where Modbus ID is 2, Function Code is 2, Start address is 1, no. of Coils is 1(bit), data string is 00.

“M3:10,3,2,3:010102020303” stands for a log entry from the second Modbus device, where Modbus ID is 10, Function Code is 2, Start address is 2, no. of Registers is 3(word), data string is 010102020303.

Data Format of EB, EN, EP, EW:

EB:battery_voltage

EN:band,signal

EP:

EW:

For device management purpose, the Data Logger will also record some important device activities as event logs, and uploading to remote server in according to the schedule rule. The types of event logs can be **EB** (Battery Low event with voltage reading), **EN** (Uplink Connection event with band number and signal strength in use), **EP** (Power ON event for alerting when the device is powered on), and **EW** (Device WakeUp for alerting when the device is waked up via external trigger).

3.2 Downlink Command Format

When you want to issue a downlink command from the remote control center to the deployed data loggers, you have to prepared a MQTT message based on the downlink command format. So that, the data logger can recognize and take the expected action accordingly.

Command Format of OTA FW Upgrade:

```
FWUpg=type;FWVer=Xaa_Ybb;FWPATH=http://file_path
```

The Data Logger supports OTA FW upgrade. It can be triggered via a OTA FW upgrade command via MQTT message. In the MQTT message payload, you have to specify the required information as avobe format.

- type :** Specify the type of OTA FW Upgrade. Currently, only type 1 is available.
 - 1:** force upgrade, ignore the version check.
 - 2:** new version replacement, version check is required. If the OTA FW version is newer or greater than that of the existing firmware, the data logger will try to get the FW and upgrade with it.
- Xaa_ybb:** Specify the FW version of OTA firmware.
- file_path:** Specify the file path (URL) of OTA firmware file. Once the data logger received the OTA FW Upgrade command, it will get the upgrade file from designated file path and then upgrade it on the device.

Command Format of DO Control:

DO=x;SN=serial_no

The Data Logger supports DO (Digital Output) Control via MQTT message. In the MQTT message payload, you have to specify the required information as above format.

- x :** Specify the DO status.
 - '0' : for OFF (output low)
 - '1' : for ON (output high)
- Serial_no :** Serial no. of the target device.
 - It can be blank for non-specific target devices that get the command.

For example,

"DO=0" stands for all the device received this command is asked to set the DO signal to low level.

"DO=1;SN=ZZ12345678" stands for the device whose serial no is ZZ12345678 is asked to set the DO signal to high level.

Contact Information

EtherWAN System, Inc.
www.etherwan.com

USA Office

2301 E. Winston Road
Anaheim, CA 9280
Tel: +1-714-779-3800
Email: info@etherwan.com

Pacific Rim Office

8F., No.2, Alley 6, Lane 235, Baoqiao Rd.
Xindian District, New Taipei City 231
Taiwan
Tel: +886 -2- 6629-8986
Email: info@etherwan.com.tw

EtherWAN has made a good faith effort to ensure the accuracy of the information in this document and disclaims the implied warranties of merchantability and fitness for a particular purpose, and makes no express warranties, except as may be stated in its written agreement with and for its customers.

EtherWAN shall not be held liable to anyone for any indirect, special or consequential damages due to omissions or errors. The information and specifications in this document are subject to change without notice.

Copyright 2020. All Rights Reserved.

All trademarks and registered trademarks are the property of their respective owners

January 10, 2020