

Temp-485-Pt100

*Temperature sensor (Pt100 or Pt1000 probe)
for the RS-485 bus, with a simple
communication
protocol*



- Temp-485-Pt100 Box2
- Temp-485-Pt100 Cable3
- Temp-485-Pt100 Frost2

Overview

Temp-485-Pt100 is a family of temperature sensors communicating over the RS-485 bus. A precise Pt100 temperature probe is used to measure the temperature. The temperature probe can be a part of the sensor, in the form of a protruding rod (“Box” version), or an external probe with a 4-wire connection.

The measured temperature is communicated directly in °C using a simple text-based protocol. Up to 31 sensors and a Poseidon unit can be connected to a single 4-wire RS-485 + power bus.

The sensor is available in the following versions (with identical function):

- **Temp-485-Pt100 Box2**
Wall-mount thermometer. The probe is in the tip of the rod protruding from the plastic box.



- **Temp-485-Pt100 Cable3**
Wall-mount box with the RS-485 / temperature probe converter. The Pt100/A probe itself (included) is connected with a 2m cable.



- **Temp-485-Pt100 Frost2**
Thermometer for measuring low temperatures, consists of a wall-mount box with the RS-485 / temperature sensor converter. The Pt100/B probe itself (included) is connected with a 2m cable.



Temp-485-Pt100 Box2

Designed for wall mounting. The probe is in the tip of the rod protruding from the plastic box. The thermometer can be wall-mounted while maintaining IP65 protection.



Probe temperature range:

-30 to +70°C (-22 to +160°F)

Accuracy:

$\pm(0.25 + 0.002|t|)$ [°C]

Sensor properties

- Measuring element: Pt100/A
- Rod length: 50 mm
- External dimensions: 62 x 144 x 35 mm
- Enclosure: IP65 (EN 60 529)
- Enclosure material: 17240 stainless steel
- Operating conditions: Relative humidity: max. 85% (at 25°C ambient temperature)

- Supply voltage: 10 to 35 VDC (protected against polarity reversal)
- Consumption while measuring: typ. 2 mA
- Consumption during RS-485 transmission: typ. 60 mA
- Wire connection: CUU 2.5 mm² terminals

RS-485 bus

- Communication: ASCII (9600Bd 8N1)
- Address configuration: software configuration or jumpers
- Termination: can be enabled with a DIP switch

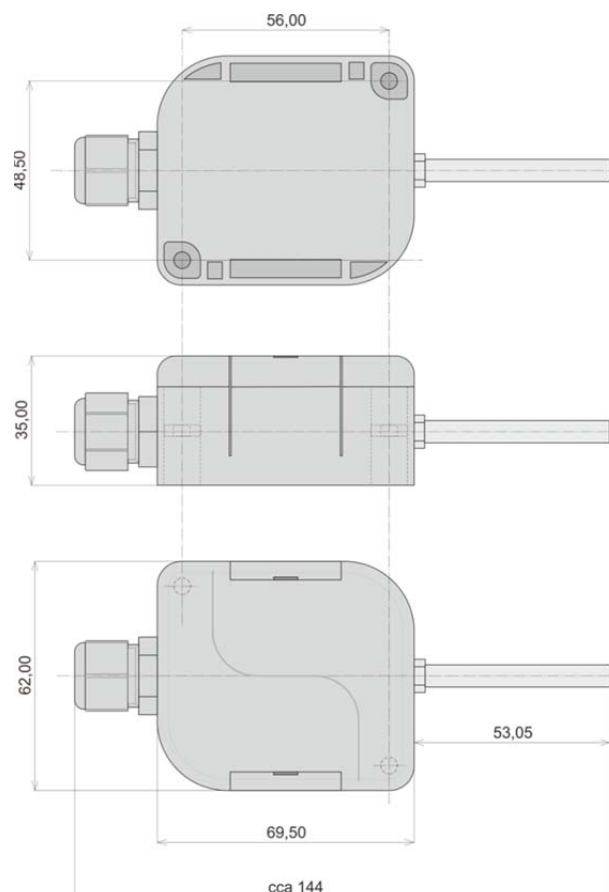

Temp-485-Pt100 Cable3

Temperature probe on a cable with a RS-485 converter in a wall-mount box.

The probe (included) is on a 2m cable in a stainless-steel rod.



Probe temperature range:	-50 to +200°C (-58 to +390°F)
Accuracy:	$\pm(0.25 + 0.002 t)$ [°C] (minimum immersion 80mm)
Converter operating conditions:	-30 to +70°C (-22 to +160°F), relative humidity max. 85%

Sensor properties

- Measuring element on the cable: Pt100/A, IP67 protection
- Cable: 2m, shielded silicone
- Rod length: 50 mm
- Probe connection: 4-wire
- Enclosure material: 17240 stainless steel
- Converter ext. dimensions: 62 x 95 x 35 mm
- Converter protection: IP65 (EN 60 529)
- Supply voltage: 10 to 35 VDC (protected against polarity reversal)
- Consumption while measuring: typ. 2 mA
- Consumption during RS-485 transmission: typ. 60 mA
- Wire connection: CUU 2.5 mm² terminals

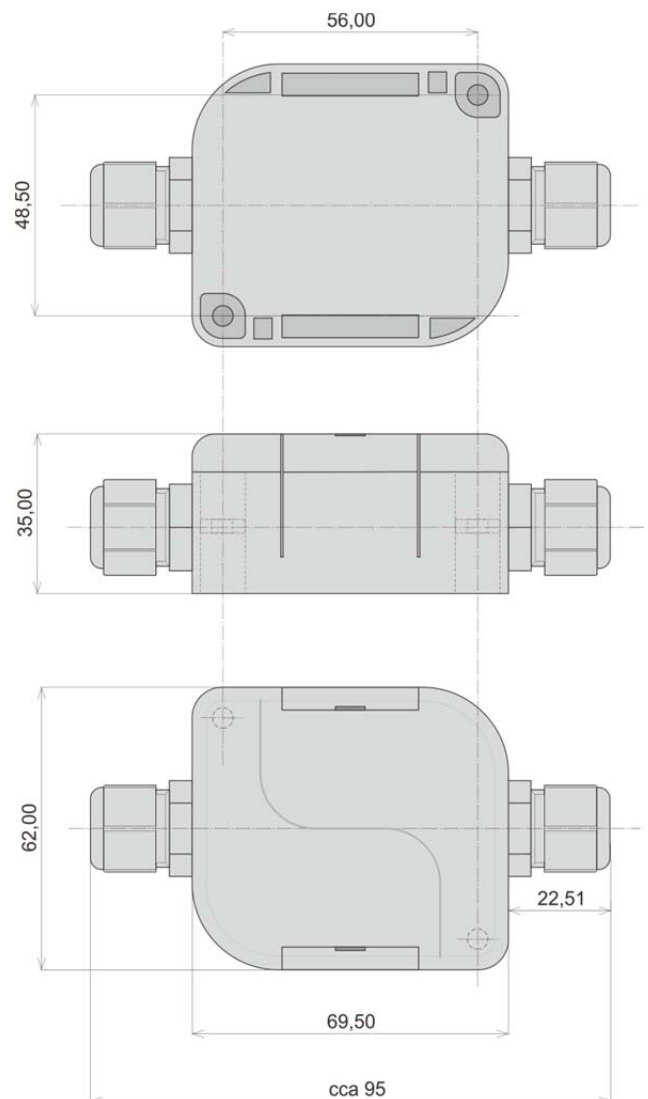

RS-485 bus

- Communication: ASCII (9600Bd 8N1)
- Address configuration: software configuration or jumpers
- Termination: can be enabled with a DIP switch

Temp-485-Pt100 Frost2

Temperature sensor for very low temperatures.

The RS-485 converter in a plastic box can be wall-mounted.

The temperature probe (included) is in a stainless-steel enclosure on a 2m teflon cable.



Probe temperature range: **-190 to +150°C (-310 to +300°F)**
 Accuracy: $\pm(0,4 + 0,005|t|)$ [°C]
 (minimum immersion 80mm, in the -100°C to +150°C range)

Converter operating conditions: **-30 to +70°C (-22 to +160°F)**, relative humidity max. 85%

Sensor properties

- Measuring element on the cable: Pt100/B, IP67 protection
- Cable: 2m, PTFE
- Rod length: 50 mm
- Probe connection: 4-wire
- Enclosure material: 17240 stainless steel
- Converter ext. dimensions: 62 x 95 x 35 mm
- Converter protection: IP65 (EN 60 529)
- Supply voltage: 10 to 35 VDC (protected against polarity reversal)
- Consumption while measuring: typ. 2 mA
- Consumption during RS-485 transmission: typ. 60 mA
- Wire connection: CUU 2.5 mm² terminals

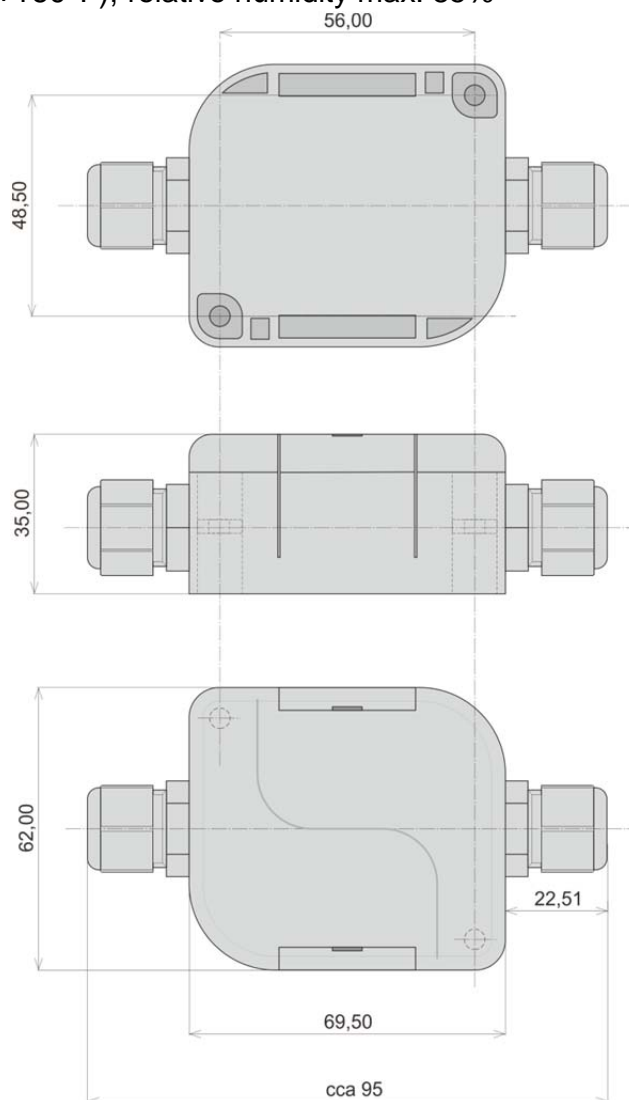

RS-485 bus

- Communication: ASCII (9600Bd 8N1)
- Address configuration: software configuration or jumpers
- Termination: can be enabled with a DIP switch

Connecting the sensor

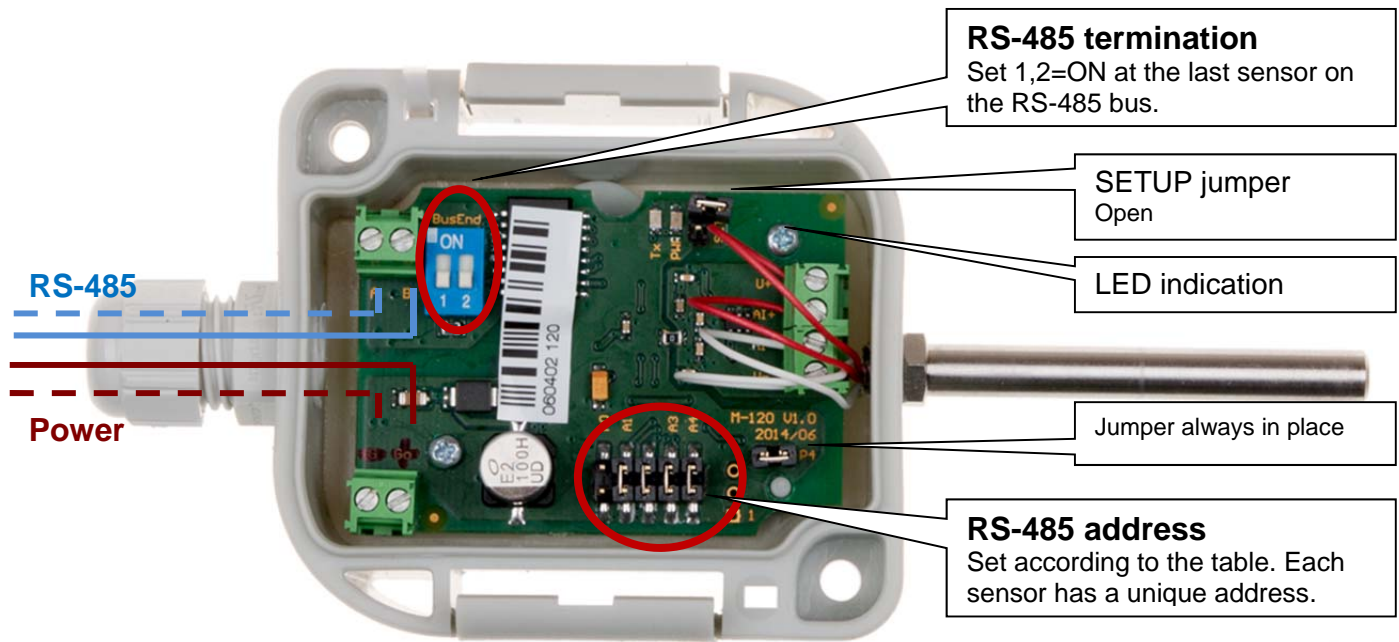

Connecting to Poseidon2 via RJ45

- Use the MIDDLE cable to connect the sensors to Poseidon2.
- However, to connect the last sensor (or the only sensor) on the RS-485 bus, use the LAST cable.
- Enable termination at the last sensor on the bus (DIP1 = ON, DIP2 = ON). All other sensors have the termination disabled (DIP1,2 = Off).

Poseidon2 RS-485 RJ45		
1		Not used
2		Not used
3		485 B return
4		RS-485 Industrial bus
5		
6		485 A return
7		Ground
8		Power

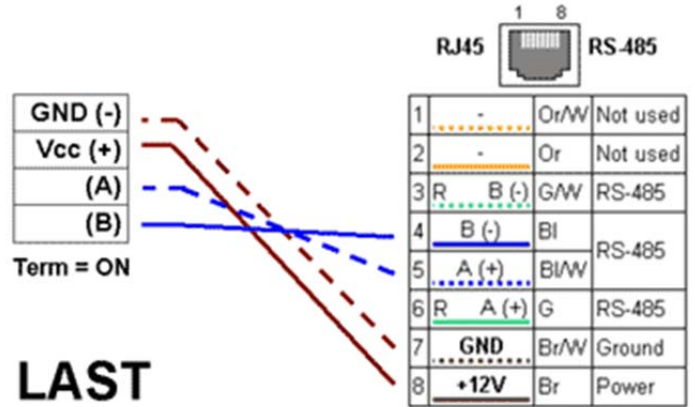
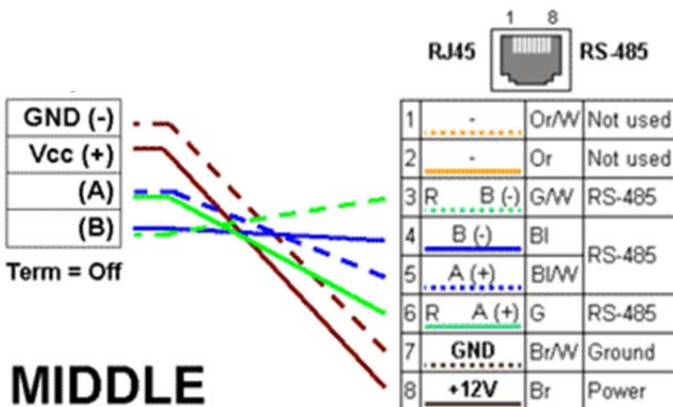

HW configuration of sensor address

Each sensor on the RS-485 bus must have a different address. The address can be configured with the A0-A4 jumpers, or using the “Telnet setup” mode in the Poseidon2 unit (see Poseidon family manual). After changing the jumpers, reset the sensor by disconnecting and reconnecting power.

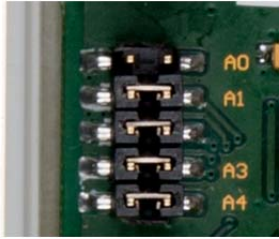

Changing the address over RS-485		RS-485 sensor address
A0 to A4	Telnet setup Poseidon2	
“A” to “Z”	Not possible	The sensor uses “A” to “Z” addresses (except “T”) according to A0 to A4 jumper settings.
“ <u>Adr by SETUP</u> ”	Possible	With this A0 to A4 jumper configuration, the address can be configured in the Telnet menu of Poseidon2. The address is a single character from the following ranges: “0”..“9”, “a”..“z”, “A”..“Z” (except “T”). The address can be also configured with a command over RS-485. Caution: When using this method of address configuration, only one sensor must be connected to the bus!

A4	A3	A2	A1	A0	Address
X	X	X	X	X	Adr by SETUP
X	X	X	X	O	A
X	X	X	O	X	B
X	X	X	O	O	C
X	X	O	X	X	D
X	X	O	X	O	E
X	X	O	O	X	F
X	X	O	O	O	G
X	O	X	X	X	H
X	O	X	X	O	I
X	O	X	O	X	J

A4	A3	A2	A1	A0	Address
X	O	X	O	O	K
X	O	O	X	X	L
X	O	O	X	O	M
X	O	O	O	X	N
X	O	O	O	O	O
O	X	X	X	X	P
O	X	X	X	O	Q
O	X	X	O	X	R
O	X	X	O	O	S
O	X	O	X	X	restricted
O	X	O	X	O	U

A4	A3	A2	A1	A0	Address
O	X	O	O	X	V
O	X	O	O	O	W
O	O	X	X	X	X
O	O	X	X	O	Y
O	O	X	O	X	Z
O	O	X	O	O	Adr by SETUP
O	O	O	X	X	Adr by SETUP
O	O	O	X	O	Adr by SETUP
O	O	O	O	X	Adr by SETUP
O	O	O	O	O	Adr by SETUP

Note: O (open) = jumper disconnected, X (closed) = jumper in place

Typical combinations:

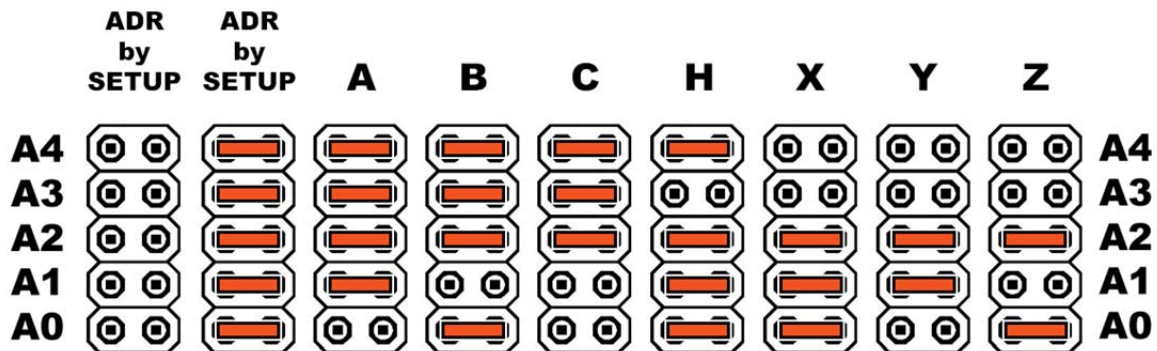

Daisy chain topology

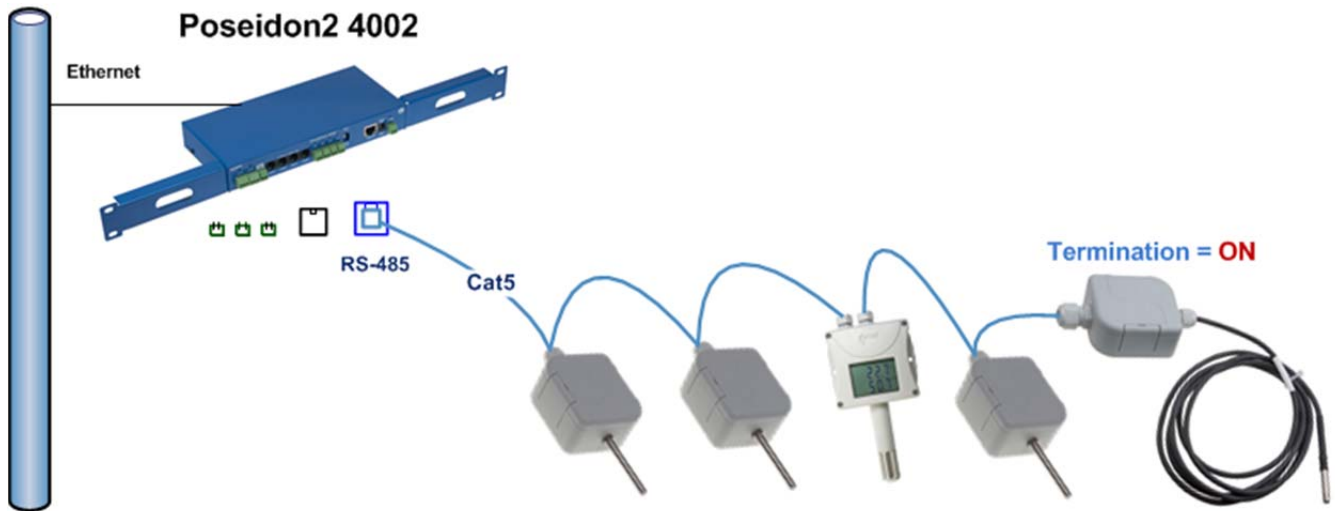

Star topology with an S-Hub

Our S-Hub unit makes it easier to connect the sensors using Cat5 cables and RJ45 jacks. In the picture below, first four sensors are connected as "MIDDLE" and the last sensor with enabled termination is connected as "LAST".

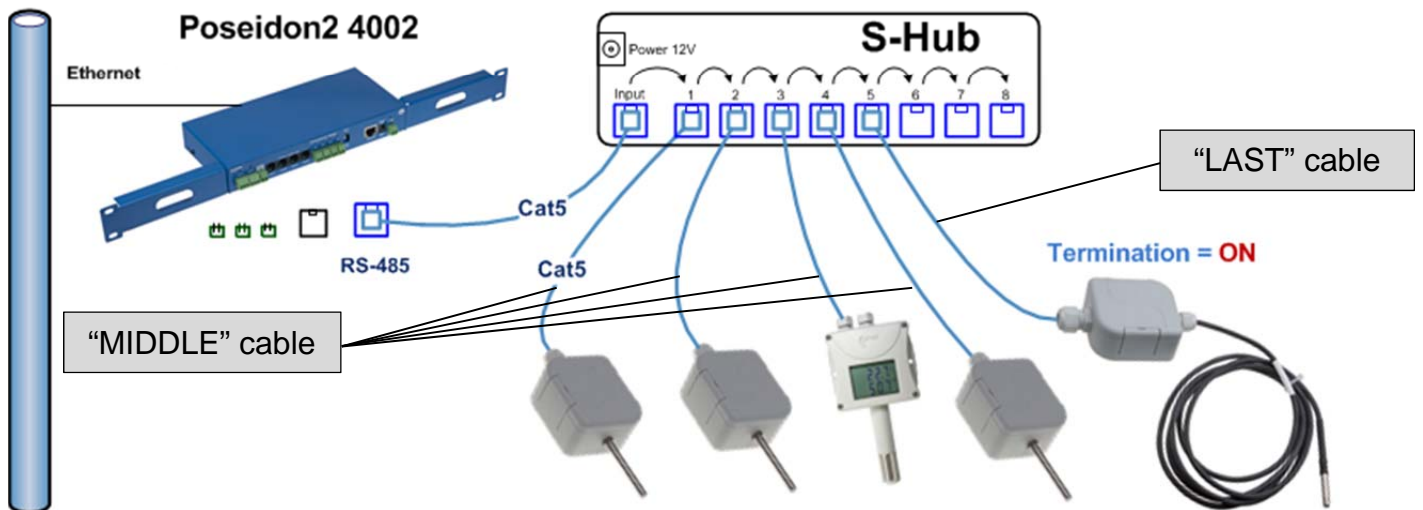
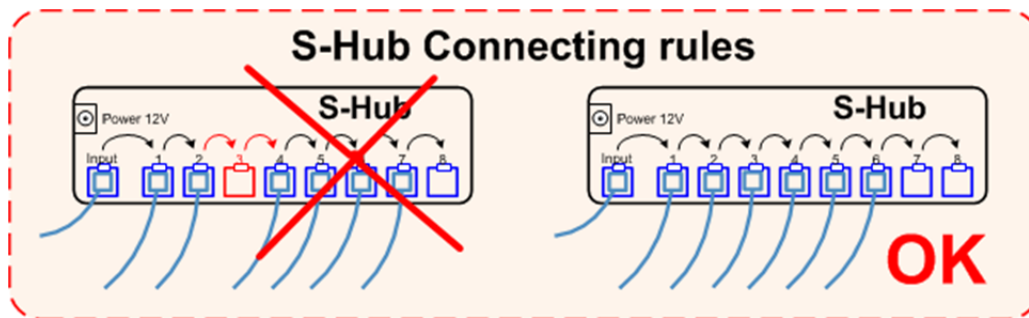

Communication protocol over RS-485

The sensors work in a request-response mode. Maximum bus response time is 20ms.

Communication bus RS-485

Address range “A” .. “Z” (except for “T”) and “a” .. “z” (25 + 26 addresses)

Communication protocol ASCII, max. response time 20 ms per command

Communication speed 9600 Bd

Data bits 8

Parity none

Stop bits 1

Reading the temperature

Function	Command format	Example
Temperature query	T<addr>I	TAI
Sensor response (all is OK)	*<addr><temp><CR>	*A+025.51C
Sensor response (error)	*<addr>Err<CR>	*AErr

<addr> is a character from “A” to “Z” or from “a” to “z” except for “T”

<CR> is the 0xD or 13 dec character – carriage return

<temp> includes two decimal spaces *A+025.55C

Device identification

Function	Command format	Example
Device type query	T<addr>?	TA?
Sensor response (all is OK)	*<addr><identifier><CR>	*ATemp-485-Pt100

<identifier> “Temp-485-Pt100” or “Temp-485-Pt1000” string

Detection of the probe type (**Pt100** or **Pt1000**) takes place automatically after power-up.

Setting sensor address

Only one sensor must be connected to the RS-485 bus and switched on. Otherwise, addresses of all connected converters change! The entire command must be sent within 3 seconds.

Caution: This must be the first command after powering up, otherwise the address does not change.

Function	Command format	Example
Address change	T#<new address>	T#A
Sensor response	*<new address>OK<CR>	*AOK

<addr> is a character from “A” to “Z” or from “a” to “z” except for “T”

<CR> is the 0xD or 13 dec character – carriage return

Note: When configuring the address of **Temp-485-2xPt100**, which in fact uses two addresses (for two temperature probes), always set the uppercase letter as the address. The other address (the same letter in lowercase) is then set automatically.

Reading, single sensor on the bus

The “\$” character is used as a wildcard address = all sensors on the RS-485 bus respond. If there is only one sensor on the bus, this can be used to discover its address.

Function	Command format	Example
Temperature query	T\$I	T\$I
Sensor response	*<addr><temp><CR>	*A+025.51C

<CR> is the 0xD or 13 dec character – carriage return

<temp> is in the *A+025.55C format

User configuration of sensor address without Poseidon2

Each sensor on the RS-485 bus must have a different address. Values are read sensor-by-sensor. The command must be sent as a single sequence of characters (max. delay between characters 1s).

Note

When setting the address with a macro that contains the “#” character (“T#A”), in some terminals this character needs to be doubled because it is normally used to insert a decimal character value.

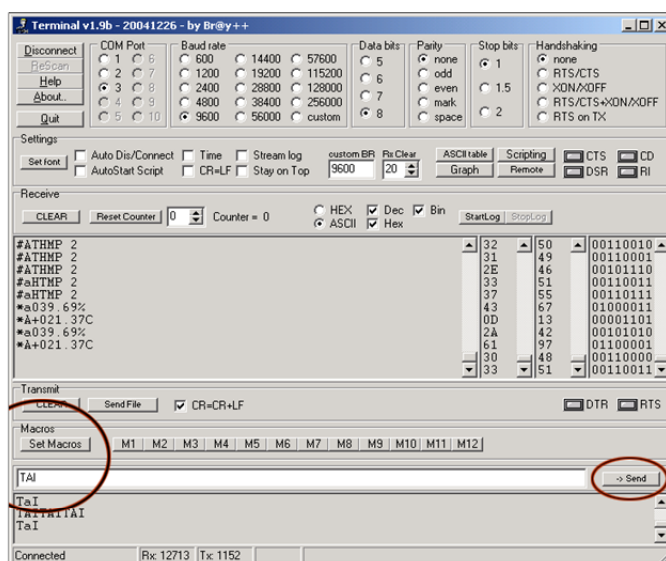
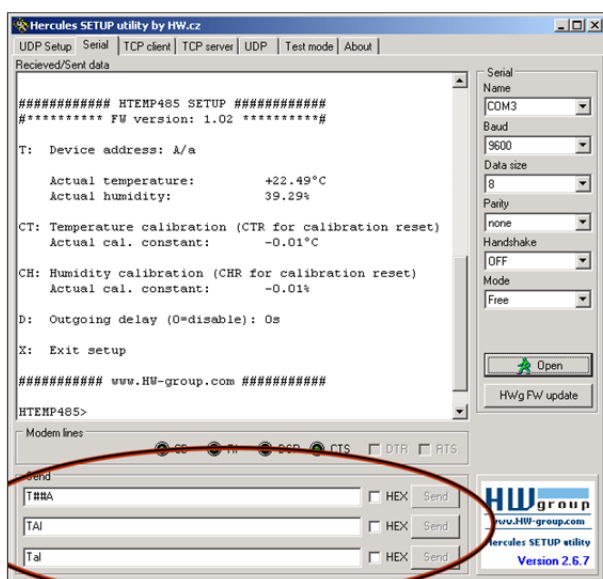

Contact

HW group s.r.o

Rumunská 26 / 122
Praha 2, 120 00, Czech republic

Tel. +420 222 511 918

Fax. +420,222,513,833



<http://www.HW-group.com>